

Owner's Manual

DC-1

Digital Controller
Base, THX® and
Dolby Digital®
Versions

lexicon

Important Safety Instructions

Save these instructions for later use.

Follow all instructions and warnings marked on the unit.

Always use with the correct line voltage. Refer to the manufacturer's operating instructions for power requirements. Be advised that different operating voltages may require the use of a different line cord and/or attachment plug.

Do not install the unit in an unventilated rack, or directly above heat producing equipment such as power amplifiers. Observe the maximum ambient operating temperature listed in the product specification.

Slots and opening on the case are provided for ventilation; to ensure reliable operation and prevent it from overheating, these openings must not be blocked or covered. Never push objects of any kind through any of the ventilation slots. Never spill a liquid of any kind on the unit.

Never attach audio power amplifier outputs directly to any of the unit's connectors.

To prevent shock or fire hazard, do not expose the unit to rain or moisture, or operate it where it will be exposed to water.

Do not attempt to operate the unit if it has been dropped, damaged, exposed to liquids, or if it exhibits a distinct change in performance indicating the need for service.

This unit should only be opened by qualified service personnel. Removing covers will expose you to hazardous voltages.

This triangle, which appears on your component, alerts you to the presence of uninsulated, dangerous voltage inside the enclosure... voltage that may be sufficient to constitute a risk of shock.



This triangle, which appears on your component, alerts you to important operating and maintenance instructions in this accompanying literature.

Adhere to all warnings on the unit and in the operating instructions.

Take precautions not to defeat the grounding or polarization of the unit's power cord.

Do not overload wall outlet, extension cords or integral convenience receptacles, as this can result in a risk of fire or electrical shock.

Route power supply cords so that they are not likely to be walked on or pinched by items placed on or against them, paying particular attention to cords at plugs, convenience receptacles, and the point at which they exit from the unit.

The unit should be cleaned only as recommended by the manufacturer.

Communications Notice

This equipment generates and uses radio frequency energy and if not installed and used properly, that is, in strict accordance with the manufacturer's instructions, may cause interference to radio and television reception. It has been type tested and found to comply with the limits for a Class B computing device in accordance with the specifications in Subpart J of Part 15 of FCC Rules, which are designated to provide reasonable protection against such interference in a residential installation. However, there is no guarantee that interference will not occur in a particular installation. If this equipment does cause interference to radio or television reception, which can be determined by turning the equipment OFF and ON, the user is encouraged to try to correct the interference by one or more of the following measures:

- Reorient the receiving antenna
- Relocate the computer with respect to the receiver
- Move the computer away from the receiver
- Plug the computer into a different outlet so that the computer and receiver are on different branch circuits.

If necessary, the user should consult the dealer or an experienced radio/television technician for additional suggestions. The user may find the following booklet prepared by the Federal Communications Commission helpful: "How to identify and Resolve Radio/TV Interference Problems." This booklet is available from the U.S. Government Printing Office, Washington, DC 20402, Stock No. 004-000-00345-4.

Le présent appareil numérique n'émet pas de bruits radioélectriques dépassant les limites applicables aux appareils numériques de la class B prescrites dans le Règlement sur le brouillage radioélectrique édicté par le ministère des Communications du Canada.

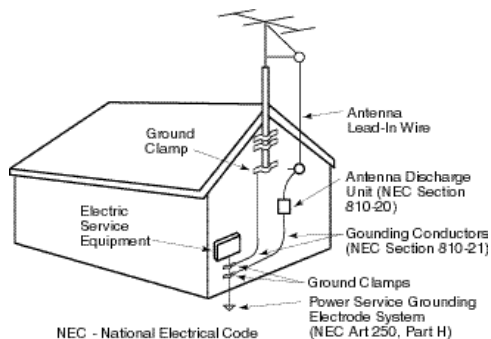

Outdoor Antenna Grounding

If an outside antenna is connected to the receiver, be sure the antenna system is grounded so as to provide some protection against voltage surges and built-up static charges. Section 810 of the National Electrical Code, ANSI/NFPA No. 70-1984, provides information with respect to proper grounding of the mast and supporting structure, grounding of the lead-in wire to an antenna-discharge unit, size of grounding conductors, location of antenna-discharge unit, connection to grounding electrodes, and requirements for the grounding electrode. See figure below.

Power Lines An outside antenna should be located away from power lines.

Acknowledgements

The DC-1 is manufactured under license from Dolby Laboratories Licensing Corporation. "Dolby", "AC-3", "Pro Logic", and the double-D symbol are trademarks of Dolby Laboratories Licensing Corporation.

The DC-1 is manufactured under license from Lucasfilm Ltd. U.S. patent numbers 5,043,970; 5,189,703; and 5,222,059. Foreign patents pending. Lucasfilm and THX are trademarks of Lucasfilm Ltd.

"Logic 7", "Auto-Azimuth" and the A-Z logo  are trademarks of Lexicon, Inc.

Copyright ©1996, 1997 Lexicon, Inc. All Rights Reserved. Lexicon Patent: U.S. no. 4, 862, 502; other patents pending on the DC-1.

Lexicon, Inc. • 3 Oak Park • Bedford MA • 01730-1441 USA • Tel: 781-280-0300 • Fax: 781- 280-0490
www.lexicon.com

Dansk

Viktig information om sikkerhed

Gem denne vejledning til senere brug.

Følg alle anvisninger og advarsler på apparatet.

Apparatet skal altid tilsluttes den korrekte spænding. Der henvises til brugsanvisningen, der indeholder specifikationer for strømforsyning. Der gøres opmærksom på, at ved varierende driftsspændinger kan det blive nødvendigt at bruge andre lednings- og/eller stiktyper.

Apparatet må ikke monteres i et kabinet uden ventilation eller lige over andet udstyr, der udvikler varme, f.eks. forstærkere. Den maksimale omgivelsestemperatur ved drift, der står opført i specifikationerne, skal overholdes.

Der er ventilationsåbninger i kabinettet. For at sikre apparatets drift og hindre overophedning må disse åbninger ikke blokeres eller tildækkes. Stik aldrig noget ind igennem ventilationsåbningerne, og pas på aldrig at spilde nogen form for væske på apparatet.

Udgangsstik fra audioforstærkere må aldrig sættes direkte i apparatet.

Apparatet må ikke udsættes for regn eller fugt og må ikke bruges i nærheden af vand for at undgå risiko for elektrisk stød og brand.

Apparatet må aldrig bruges, hvis det er blevet stødt, beskadiget eller vådt, eller hvis ændringer i ydelsen tyder på, at det trænger til eftersyn.

Dette apparat må kun åbnes af fagfolk. Hvis dækslet tages af, udsættes man for livsfarlig højspænding.



Denne mærkat på komponenten advarer om uisoleret, farlig spænding i apparatet ... høj nok til at give elektrisk stød.



Denne mærkat på komponenten advarer om vigtig drifts- og vedligeholdelsesinformation i den tilhørende litteratur.

Suomi

Tärkeitä turvallisuusohjeita

Säilytä nämä ohjeet tulevaa käyttöä varten.

Seuraa kaikkia yksikköön merkittyjä ohjeita ja varoituksia.

Käytä aina oikeaa verkkojännitettä. Tehovaatimukset selviävät valmistajan käyttöohjeista. Huomaa, että eri käyttöjännitteet saattavat vaatia toisenlaisen verkkojohdon ja/tai -pistokkeen käytön.

Älä asenna yksikköä telineeseen jossa ei ole tuuletusta, tai välittömästi lämpöä tuottavien laitteiden, esim. tehovahvistimien, yläpuolelle. Ympäristön lämpötila käytössä ei saa ylittää tuotespesifikaation maksimilämpötilaa.

Kotelo on varustettu tuuletusreillä ja -aukoilla. Luotettavan toiminnan varmistamiseksi ja ylläpitämisen välttämiseksi näitä aukkoja ei saa sulkea tai peittää. Mitään esineitä ei saa työntää tuuletusaukkoihin. Mitään nesteitä ei saa kaataa yksikköön.

Älä kytke audiotehovahvistimen lähtöjä suoraan mihinkään yksikön liittimeen.

Sähköiskun ja palovaaran välttämiseksi yksikkö ei saa olla sateessa tai kosteassa, eikä sitä saa käyttää märässä ympäristössä.

Älä käytä yksikköä jos se on pudonnut, vaurioitunut, kostunut, tai jos sen suorituskyky on huomattavasti muuttunut, mikä vaatii huoltoa.

Yksikön saa avata vain laitteeseen perehtynyt huoltohenkilö. Kansien poisto altistaa sinut vaarallisille jännitteille.



Tämä kolmio, joka esiintyy komponentissasi, varoittaa sinua eristämättömän vaarallisen jännitteen esiintymisestä yksikön sisällä. Tämä jännite saattaa olla riittävän korkea aiheuttamaan sähköiskuvaaran.



Tämä kolmio, joka esiintyy komponentissasi, kertoo sinulle, että tässä tuotedokumentoinnissa esiintyy tärkeitä käyttö- ja ylläpito-ohjeita.

Norsk

Viktig informasjon om sikkerhet

Ta vare på denne veiledningen for senere bruk.

Følg alle anvisningene og advarslene som er angitt på apparatet.

Apparatet skal alltid anvendes med korrekt spenning. Produktbeskrivelsen inneholder spesifikasjoner for strømkrav. Vær oppmerksom på at det ved ulike driftsspenninger kan være nødvendig å bruke en annen lednings- og/eller støpseltype.

Apparatet skal ikke monteres i skap uten ventilasjon, eller direkte over varmeproduserende utstyr, som for eksempel kraftforstærkere. Den maksimale romtemperaturen som står oppgitt i produktbeskrivelsen, skal overholdes.

Apparatet er utstyrt med ventilasjonsåpninger. For at apparatet skal være pålitelig i bruk og ikke overopphetes, må disse åpningene ikke blokeres eller tildekkes. Stikk aldri noe inn i ventilasjonsåpningene, og pass på at det aldri søles noen form for væske på apparatet.

Utgangspluggene fra audioforstærkere skal aldri koples direkte til apparatet.

Unngå brannfare og elektrisk støt ved å sørge for at apparatet ikke utsettes for regn eller fuktighet og ikke anvendes i nærheten av vann.

Apparatet skal ikke brukes hvis det har blitt utsatt for støt, er skadet eller blitt vått, eller hvis endringer i ytelsen tyder på at det trenger service.

Dette apparatet skal kun åpnes av fagfolk. Hvis dekslet fjernes, utsettes man for livsfarlig høyspenning.



Komponenten er merket med denne trekanten, som er en advarsel om at det finnes uisoleret, farlig spenning inne i kabinettet ... høy nok til å utgjøre en fare for elektrisk støt.



Komponenten er merket med denne trekanten, som betyr at den tilhørende litteraturen inneholder viktige opplysninger om drift og vedlikehold.

Svenska

Viktiga säkerhetsföreskrifter

Spara dessa föreskrifter för framtida bruk.

Följ alla anvisningar och varningar som anges på enheten.

Använd alltid rätt nätspänning. Se tillverkarens bruksanvisningar för information om effektkrav. Märkväl, att andra matningsspänningar eventuellt kräver att en annan typs nätsladd och/eller kontakt används.

Installera inte enheten i ett oventilerat stativ, eller direkt ovanför utrustningar som avger värme, t ex effektförstärkare. Se till att omgivningens temperatur vid drift inte överskrider det angivna värdet i produktspecifikationen.

Behållaren är försedd med hål och öppningar för ventilering. För att garantera tillförlitlig funktion och förhindra överhettning får dessa öppningar inte blockeras eller täckas. Inga föremål får skuffas in genom ventilationshålen. Inga vätskor får spillas på enheten.

Anslut aldrig audioeffektförstärkarutgångar direkt till någon av enhetens kontakter.

För att undvika elstöt eller brandfara får enheten inte utsättas för regn eller fukt, eller användas på ställen där den blir våt.

Använd inte enheten om den har fallit i golvet, skadats, blivit våt, eller om dess prestanda förändrats märkbart, vilket kräver service.

Enheten får öppnas endast av behörig servicepersonal. Farliga spänningar blir tillgängliga när locken tas bort.



Denna triangel, som visas på din komponent, varnar dig om en oisolerad farlig spänning inne i enheten. Denna spänning är eventuellt så hög att fara för elstöt föreligger.



Denna triangel, som visas på din komponent, anger att viktiga bruksanvisningar och serviceanvisningar ingår i dokumentationen i fråga.

Deutsch
Wichtige Sicherheitsanweisungen

Heben Sie sich diese Sicherheitsanweisungen auch für später auf.
Befolgen Sie alle auf der Vorrichtung stehenden Anweisungen und Warnungen. Immer nur mit der richtigen Spannung verwenden! Die Gebrauchsanweisungen des Herstellers informieren Sie über die elektrischen Anforderungen. Vergessen Sie nicht daß bei verschiedenen Betriebsspannungen ggf. auch verschiedene Leitungskabel und/oder Verbindungsstecker zu verwenden sind.
Stellen Sie die Vorrichtung nicht in ein unbelüftetes Gestell oder unmittelbar über wärmeerzeugende Geräte wie z.B. Tonverstärker. Halten Sie die in den Produktspezifikationen angegebene maximale Umgebungstemperatur bei Betrieb ein.
Schlitze und Öffnungen im Gehäuse dienen der Belüftung; um verlässlichen Betrieb sicherzustellen und Überheizen zu vermeiden dürfen diese Öffnungen nicht verstopft oder abgedeckt werden. Stecken Sie nie irgend einen Gegenstand durch die Belüftungsschlitze. Vergießen Sie keine Flüssigkeiten auf den Apparat.
Schließen Sie nie Tonverstärker unmittelbar an einen Anschluß des Apparates an.
Um elektrischen Schlag oder Feuer zu vermeiden, setzen Sie den Apparat weder Regen noch Feuchtigkeit aus und betreiben Sie ihn nicht dort wo Wasser eindringen könnte.
Versuchen Sie nicht den Apparat zu betreiben falls er fallen gelassen, beschädigt, oder Flüssigkeiten ausgesetzt wurde, oder falls sich seine Arbeitsweise derart ändert daß daraus ein Bedarf nach Reparatur zu schließen ist.
Dieser Apparat sollte nur von qualifizierten Fachleuten geöffnet werden. Das Abnehmen von Abdeckungen setzt Sie gefährlichen Spannungen aus.



Dieses Dreieck auf Ihrem Apparat warnt Sie vor nicht-isolierter, gefährlicher Spannung im Gehäuse ... stark genug um eine Berühungsgefahr darzustellen.



Dieses Dreieck auf Ihrem Apparat bedeutet daß wichtige Betriebs- und Wartungsanweisungen in der mitgelieferten Dokumentation zu finden sind.

Español
Instrucciones importantes de seguridad

Guarde esta instrucciones para uso posterior.
Utilice siempre el voltaje correcto. Dirijase a las instrucciones de operación del fabricante para obtener las especificaciones de potencia. Esté al tanto de que voltajes de operación distintos requieren el uso de cables y/o enchufes distintos.
No instale esta unidad en un estante sin ventilación, ni tampoco directamente encima de equipos que generen calor tales como amplificadores de potencia. Fijese en las temperaturas ambientales máximas de operación que se mencionan en las especificaciones del producto.
Las aperturas y ranuras del chasis sirven para proveer la ventilación necesaria para operar la unidad con seguridad y para prevenir sobrecalentamiento, y por lo tanto no pueden ser obstruidas o cubiertas. No introduzca objetos de ningún tipo a través de las ranuras de ventilación, y nunca deje caer ningún líquido sobre la unidad.
Nunca conecte ningún tipo de salida de amplificadores de sonido directamente a los conectores de la unidad.
Para prevenir descargas eléctricas o incendios, mantenga la unidad alejada de la lluvia, humedad o cualquier lugar en el que pueda entrar en contacto con agua.
No trate de hacer funcionar la unidad si se ha caído, está dañada, ha entrado en contacto con líquidos, o si nota cualquier cambio brusco en su funcionamiento que indique la necesidad de hacerle un servicio de mantenimiento.
Esta unidad deberá ser abierta únicamente por personal calificado. Si usted quita las coberturas se expondrá a voltajes peligrosos.



Este triángulo que aparece en su componente le advierte sobre la existencia dentro del chasis de voltajes peligrosos sin aislantes ... voltajes que son lo suficientemente grandes como para causar electrocución.



Este triángulo que aparece en su componente lo alerta sobre las instrucciones de operación y mantenimiento importantes que están en los materiales de lectura que se incluyen.

Français
Instructions de Sécurité Importantes

Gardez ces instructions pour référence future.
Observez toutes les instructions et tous les avertissements marqués sur l'appareil.
Branchez uniquement sur un réseau de tension indiquée. Consultez le manuel d'instruction du fabricant pour les spécifications de courant. N'oubliez pas que différentes tensions peuvent nécessiter l'utilisation de câbles et/ou de fiches de connexion différents.
N'installez pas l'appareil en un compartiment non-aéré ou directement au-dessus d'équipements générateurs de chaleur, tels qu'amplificateurs de courants, etc. Ne dépassez pas la température ambiante maximale de fonctionnement indiquée dans les spécifications du produit.
Des fentes et ouvertures sont prévues dans le boîtier pour l'aération; Pour assurer le bon fonctionnement et pour prévenir l'échauffement, ces ouvertures ne doivent pas être couvertes ou bloquées. N'insérez pas d'objets dans les fentes d'aération. Empêchez tout liquide de se répandre sur l'appareil.
Ne connectez jamais d'amplificateurs audio directement aux connecteurs de l'appareil.
Pour empêcher les chocs électriques et le danger d'incendie, évitez d'exposer l'appareil à la pluie ou à l'humidité, et ne le mettez pas en marche en un endroit où il serait exposé aux éclaboussures d'eau.
N'essayez pas de faire fonctionner l'appareil s'il est tombé à terre, a été endommagé, exposé à un liquide, ou si vous observez des différences nettes dans son fonctionnement, indiquant la nécessité de réparations.
Cet appareil ne doit être ouvert que par un personnel de service qualifié. En enlevant les couvercles vous vous exposez à des tensions électriques dangereuses.



Ce triangle, sur votre appareil vous avertit de la présence de tension dangereuse, non-isolée à l'intérieur du boîtier...une tension suffisante pour représenter un danger d'électrocution.



Ce triangle sur sur votre appareil vous invite de suivre d'importantes instructions d'utilisation et d'entretien dans la documentation livrée avec le produit.

Italiano
Importanti norme di sicurezza

Conservare le presenti norme per l'utilizzo futuro.
Osservare tutte le istruzioni e le avvertenze apposte sull'unità.
Utilizzare esclusivamente con la tensione di rete corretta. Consultare le istruzioni operative fornite dal fabbricante per i dati riguardanti la tensione e l'assorbimento di corrente. Potrebbe essere necessario l'uso di cavi di rete e/o di spine diverse a seconda della tensione utilizzata.
Non installare l'unità in uno scaffale privo di ventilazione oppure direttamente sopra una fonte di calore, come, ad esempio, un amplificatore. Non superare la temperatura ambientale massima di funzionamento riportata nei dati tecnici del prodotto.
Le fessure e le altre aperture nella scatola servono alla ventilazione. Per un funzionamento affidabile, e per evitare un eventuale surriscaldamento, queste aperture non vanno ostruite o coperte in nessun modo. Evitare in tutti i casi di inserire oggetti di qualsiasi genere attraverso le fessure di ventilazione. Non versare mai del liquido di nessun tipo sull'unità.
Evitare sempre di collegare le uscite dell'amplificatore audio direttamente ai connettori dell'unità.
Per prevenire il pericolo di folgorazione e di incendio non esporre l'unità alla pioggia o ad un'umidità eccessiva; evitare di adoperare l'unità dove potrebbe entrare in contatto con acqua.
Evitare di adoperare l'unità se la stessa è stata urtata violentemente, se ha subito un danno, se è stata esposta ad un liquido o in caso di un evidente cambiamento delle prestazioni che indichi la necessità di un intervento di assistenza tecnica.
Ogni intervento sull'unità va eseguito esclusivamente da personale qualificato. La rimozione della copertura comporta l'esposizione al pericolo di folgorazione.



Il presente triangolo impresso sul componente avverte della presenza di tensioni pericolose non isolate all'interno della copertura... tali tensioni rappresentano un pericolo di folgorazione



Il presente triangolo impresso sul componente avverte l'utente della presenza nella documentazione allegata di importanti istruzioni relative al funzionamento ed alla manutenzione.

Owner's Manual

DC-1

Digital Controller
Base, THX® and
Dolby Digital®
Versions

lexicon

Contents

1	Introduction to the DC-1	1
	Introduction	1
	Unpacking and Inspection	5
	Using the Documentation	5
	System Overview	6
	Glossary of Terms	6
	DC-1 Block Diagram	7
2	Installation and Calibration	9
	Controls and Indicators	9
	The Front Panel	9
	The Rear Panel	10
	The Remote Control	11
	Remote Control ACCY Functions	
	Connection	13
	Location Considerations	13
	AC Connections	13
	Wiring Considerations	14
	Audio/Video Cables • Speaker Connections	
	Audio/Video Connections	14
	Connecting the DC-1 as a preamp	15
	Video Connections	16
	Digital Audio Connections	16
	"AC-3 Ready" Laser Disc and LD/DVD Players	
	Recording a Digital Source Using the DC-1	
	D/A Converter	17
	Digital Input Status Detection	17
	RECORD/ZONE 2 Operation	18
	Zone 2 Remote Control • Exclusive Zone 2 Control	
	System Configuration	21
	Display Adjustment	21
	The Video On-Screen Display	22
	System Setup	23
	Input Configuration • Input Gain • Input Level Meters • Input Name • Restore Input Name • Input Effect Assignment • Digital Audio Input Assignment • Video Input Assignment • Record/Zone 2 Output Blocking • Remote Trigger Assignment	
	Setting the Speaker Configuration	27
	Front L/R • Center • Sides • Rears Subwoofer Output	
	Setting Output Levels	29
	Subwoofer Peak Limiter (Dolby Digital version) • Mute Level • Power On Volume Zone 2 Volume	

Contents, cont'd.		
	Setting Listener Position	32
	Surround Delay • Time Alignment (Dolby Digital version) • Center Delay (Base and THX versions) • A/V Sync Delay (Dolby Digital version) • Calibrate Panorama	
	Customization	36
	Locking Settings	36
	Assign Custom Name	36
	Audio Bit Setting (Dolby Digital Version)	36
	Equalization (THX and Dolby Digital versions)	37
	Bass and Treble Level • Tilt (Dolby Digital version) • Loudness	
3	DC-1 Effects	39
	Customizing Effects	39
	Comparing a modified Effect to the factory preset version • Restoring the original parameter values of an Effect • Naming your custom Effect • Restoring the original Effect Name • Listening to only the DC-1 Effect	
	Music Surround (THX and Dolby Digital versions)	41
	Pro Logic	42
	THX Cinema (THX and Dolby Digital versions)	43
	Logic 7 (THX and Dolby Digital versions)	44
	TV Matrix	46
	Mono Logic	48
	Panorama	49
	Nightclub	51
	Concert Hall	52
	Church	53
	Cathedral	54
	Music Logic	55
	Party	57
	Two Channel	57
	AC-3 Status Display (Dolby Digital version)	58
	5.1 Music (Dolby Digital version)	59
	Dolby Digital (Dolby Digital version)	60
	THX 5.1 (Dolby Digital version)	61
	5.1 Logic 7 (Dolby Digital version)	62
	5.1 Two Channel (Dolby Digital version)	64
4	Troubleshooting	65
5	Specifications	69

Installation Documentation

Introduction

More than just a surround processor, the DC-1 is a digital control center with state-of-the-art performance and flexibility. A superb line level preamp, the DC-1 provides 8 audio, 5 video (3 S-VHS), and 4 digital (2 coaxial, 2 optical) inputs. The video and digital inputs can be assigned to any of the audio inputs for custom configuration. The digital inputs are processed through true 20-bit D/A converters, providing a level of performance not found in most stand-alone converters. Built-in digital crossovers make it possible to tailor the output to match any speakers in a system. There is also a second set of pre-outs with independent volume and source selection to accommodate music in a separate zone.

A great deal of effort went into designing an instrument which would be flexible enough to satisfy the most critical listeners and yet be simple to operate. Essentially, the DC-1 is a signal processing computer that can be custom-programmed for any specific system. Once installed, it can be operated easily via a remote, providing effects tailored for your specific listening environment, and complete control of every aspect of operation.

The Lexicon DC-1 Digital Controller has a single goal: to draw you, the listener, more deeply into a musical performance or film. For music the DC-1 uses 5 or 7 channel digital processing to recreate the original recording space, or true stereo synthesis to create a new one of your choosing. For films, it offers Dolby Digital and Lexicon's proprietary Logic 7™ enhancements to Pro Logic® surround decoding, along with the enhancements of the Lucasfilm® Home THX Cinema system. The increase in impact of a musical performance or film heard with the DC-1 is incredible.

To recreate the experience of being at a live musical performance, the DC-1 draws on ongoing studies of concert hall acoustics, and applies this research to home listening rooms. Our auditory sense is quite adept at interpreting clues about our physical environment. Even with your eyes closed, it is possible to get a good mental picture of the room or hall you are in by listening to the ambience, or reflected sound energy, in the room. We are not aware of our auditory perception of space in everyday life because it confirms what our eyes readily see. When we listen to recorded music, however, there are no visual clues and we rely completely on our sense of hearing.

More than thirty years ago, the introduction of two-speaker stereo systems brought dramatic improvement to high fidelity music reproduction. With a carefully designed system, and good recording, it became possible to produce a sonic picture of the original event. But, like a photograph hanging on a wall, conventional stereo is a two dimensional snapshot of the original event. We can appreciate the likeness, but the picture stays in front of us while we stay in our listening room. The DC-1 is designed to overcome this fundamental limitation of two-speaker reproduction and bring us closer to the ultimate goal of transporting ourselves to the original musical event.

The key to our perception of the acoustic space we inhabit lies in the lateral sound field – the sound which moves from side to side in the room. The two front speakers used in conventional two channel stereo do not adequately excite these lateral fields in a playback room. The speakers are too far forward, and the ambient information in the recording is often masked by the music itself. The DC-1 extracts or synthesizes the ambient information, and uses additional speakers along the sides and rear of the room to create a lateral field which closely emulates the original. If the system does not have side or rear loudspeakers the DC-1 can use panorama technology to simulate them.

The object is to generate signals for the sides and rear speakers which recreate the lateral sound missing in conventional stereo. The most basic approach to this is to analyze the incoming material and extract from it the information which should be reproduced from the sides and the rear. As this is also the object of any standard matrix film decoder, one might think the technology for doing this was well understood, but it is not so easy. Matrix film decoders evolved from early Quad decoders and are limited to four decoded channels: front left, front center, front right, and rear. When the single rear channel is reproduced from multiple speakers in a small playback room, the sound from the different speakers interferes with itself, creating a non-enveloping soundfield with an unpleasant timbre. Although there have been decoders in the past with the ability to separate directionally encoded effects into more than four directions, they have all suffered from reduced separation of the rear channels during playback of music. The DC-1 solves this basic problem with a new idea: a 5 or 7 channel decoder which is completely compatible with a standard decoder for any directionally encoded effect, but which maintains the maximum difference between the left and right side/rear channels at all times.

This new technology is available in the THX and Dolby Digital versions of the DC-1 in several effects. The basic effect for films is Logic 7, and the basic effect for music is Music Surround. All the new 5 and 7 channel effects extract the spatial content hidden in two channel recordings and spread it convincingly around the listener. All DC-1 matrix decoding algorithms also include Lexicon's patented correction circuits for balance and azimuth errors in the original source material, which make our decoders the most accurate in the industry. The difference between the new 5 or 7 channel technology and the older 4 channel technology (also present in the DC-1 as the Pro-Logic effect and the standard THX Cinema effect) is easily heard through the increase in envelopment with music or the environmental sound of any film, and through the increased listener area and spaciousness on a music CD.

Logic 7 technology also lets us reproduce directionally encoded effects with left/right separation in the rear. Thus even with a conventional 4-2-4 matrix-encoded soundtrack (Dolby Surround, Ultra*Stereo, etc.) a sound effect which pans from left to rear will decode in the DC-1 first from the left front speaker, then from the left side speaker, and finally from both rear speakers. The results on a film with a good soundtrack are spectacular.

The DC-1 also has the ability to create an acoustic environment which is not present on the original recording. Using the Nightclub, Concert Hall, Church and Cathedral effects, you can select the acoustics the digital processor will simulate. Each of these effects has many adjustments to allow you to generate just the right sound for a particular piece of music in your room. In addition, the DC-1 includes the Panorama effect, which cancels the crosstalk between the listener's ears, and spreads the sound from just two loudspeakers into a wide arc. A listener in the right spot is completely enveloped by the original sound field of the recording.

The Dolby Digital version of the DC-1 opens a whole new world of lateral sound. With AC-3 encoded source material the DC-1 plays 5 discrete channels plus a low frequency effects (LFE) channel as the original sound producer intended – from speakers all around the listener. When 7 speakers are available, the 5.1 Logic 7 effect uses Lexicon matrix technology and delay to differentiate between the side speakers and the rear speakers. The improvement in envelopment over standard 5.1 channel decoding is not subtle. Like Logic 7 for two channel matrix encoded film, we find the 5.1 Logic 7 effect gives the highest standard of 5.1 channel reproduction currently available. Enhancements to Dolby Digital AC-3 are available in the THX 5.1 effect, and some of these are included as parameters in 5.1 Logic 7. The Dolby Digital version of the DC-1 also includes effects for optimally reproducing 5.1 channel encoded music, as well as the original Dolby Digital 5.1 channel effect. The 5.1 Two Channel effect allows material encoded in AC-3 with 5.1 channels to be downmixed to two channels while preserving the encoded surround information. This version can then be played back through a surround effect such as Pro Logic or Logic 7. The DC-1 also provides effects for expanding monaural sources (Mono Logic), general TV viewing (TV Matrix), background music (Party) and, of course, Two Channel stereo playback.

Designed with an eye toward the future, the DC-1's open architecture allows upgrades via simple modifications which can be performed by any Lexicon dealer. With its blend of performance and flexibility, the DC-1 will deliver the full potential of music and movies for years to come.

About Dolby Digital AC-3 encoding

Because multichannel recordings are made up of so much information, new ways of storing and transmitting it have had to be created. To this end, Dolby Laboratories developed AC-3, a digital audio coding technique on which the Dolby Digital surround format is based.

On a typical compact disc, 16-bit samples are taken 44,100 times per second for each channel, which allows as much as 74 minutes of 2 channel audio on a single CD. However, if a digital recording consists of 6 channels up to two hours in length, storage or transmission becomes impractical due to the immense amount of data. Because of this, new forms of digital audio coding (sometimes referred to as "perceptual coding") have been developed to allow the use of lower data rates with a minimum of perceived degradation of sound quality.

Designed specifically to handle multichannel audio, AC-3 takes advantage of a psychoacoustic phenomenon known as auditory masking. It divides the audio spectrum of each channel into narrow frequency bands of different sizes optimized with respect to the frequency selectivity of human hearing. This makes it possible to sharply filter coding noise so that it is forced to stay very close in frequency to the frequency components of the audio signal being coded. By reducing or eliminating coding noise whenever there are no audio signals to mask it, the sound quality of the original signal can be subjectively preserved. The result is multichannel sound that is subjectively equal to 2 channel digital recordings, yet can be stored and transmitted efficiently.

AC-3 can process at least 20-bit dynamic range digital audio signals over a frequency range from 20Hz to 20kHz. The bass effects channel covers 20 to 120Hz. Data rates range from 32kb for a single mono channel to as high as 640 kb.

Dolby Digital source material has been released to date on many laser discs. These discs, while able to deliver two channels of PCM digital audio, are not capable of storing an additional six channels of digital audio information. The AC-3 bitstream is, therefore, converted into a frequency modulated signal (referred to as the AC-3 RF signal) and stored on the right channel analog track of AC-3 encoded laser discs. This signal must be demodulated, or turned back into a digital signal, before it can be decoded by the DC-1.

Several manufacturers provide equipment which will perform the necessary demodulation. Lexicon's LDD-1 is designed specifically to provide external AC-3 RF demodulation and auto switching with minimal degradation of performance due to RF interference.

Other AC-3 formats, such as DVD, output AC-3 code as a digital signal, and do not require demodulation.

After unpacking the DC-1, save all packing materials in case you ever need to ship the unit. Thoroughly inspect the DC-1 and packing materials for signs of damage. Remove the adhesive protective film from the DC-1 front-panel lens and remote control. Report any shipment damage to the carrier at once; report equipment malfunction to your dealer.

Unpacking and Inspection

Because the DC-1 is designed to be customized for your system and your listening space, the information required for installation is extensive.

Using the Documentation

This manual describes the DC-1 base system, the THX version and the Dolby Digital version, which incorporates all of the THX enhancements in addition to the Dolby Digital features. Features which are available only in certain versions are noted wherever appropriate. To upgrade a base or THX system, contact your dealer, or Lexicon. In most cases, upgrading can be accomplished very easily and rapidly.

The Owner's Manual is designed to assist you in installing, calibrating and operating the DC-1. It should be used in conjunction with the remote control when configuring the system to perform optimally in your environment. This manual was written with the underlying assumption that the installer is familiar with audio/video system installation.

An Installation Worksheet is provided at the end of this manual for documentation of the settings arrived at during the calibration procedure.

System Overview

Although the DC-1 performs very complex signal processing, a great deal of effort has gone into making the technology behind the effects as transparent as possible to the user. To understand the overall organization of the unit, it is helpful to define those few terms which are unique to the DC-1.

Glossary of Terms

Effect An *effect* is a configuration that determines how the DC-1 will process an input signal. The base unit contains 11 effects: *Pro Logic*, *TV Matrix*, *Mono Logic*, *Panorama*, *Nightclub*, *Concert Hall*, *Church*, *Cathedral*, *Music Logic*, *Party and Two Channel*. The THX version of the DC-1 contains these effects as well as *Music Surround*, *THX Cinema* and *Logic 7*. The Dolby Digital version contains all of the above effects as well as *5.1 Music*, *Dolby Digital*, *THX 5.1*, *5.1 Logic 7* and *5.1 Two Channel*.

Parameter Each Effect has a set of *parameters* (controls) that uniquely characterize it. The settings of the parameters can be changed to customize each Effect.

Effect Parameter values are stored/recalled with each Effect. Some examples are: Rolloff, Subwoofer Level, etc.

System parameter values are not associated with a particular Effect and their values do not change when a new Effect is loaded. Examples are: display contrast, volume, etc.

Presets The DC-1 contains a set of Effects with factory-set parameters. You can use these Effects as is, or make changes to the parameters to suit your own needs. The factory parameter settings are permanently stored in memory where they can be accessed for comparison with your own versions, or restored.

Essentially, the DC-1 can be thought of as a line level preamp D/A converter with three audio-only, five audio/video, and four digital inputs. It behaves as the master processor for your system, controlling system volume, balance, source selections, output selections for audio and video, and acoustical environments specifically designed for music and movies.

The remote control provided with the DC-1 is designed for simple daily use, as well as for use in configuring the DC-1 to work optimally with your system. The remote gives you access to setup controls and parameter menus for all of the DC-1 Effects.

In many systems, a learning remote such as the Lexicon 500T may take the place of the DC-1 remote. If you are using one of these, we strongly suggest that the types of operating controls we have provided be adapted into the universal remote. We have found these controls enhance the listening/viewing experience while keeping the technology transparent.

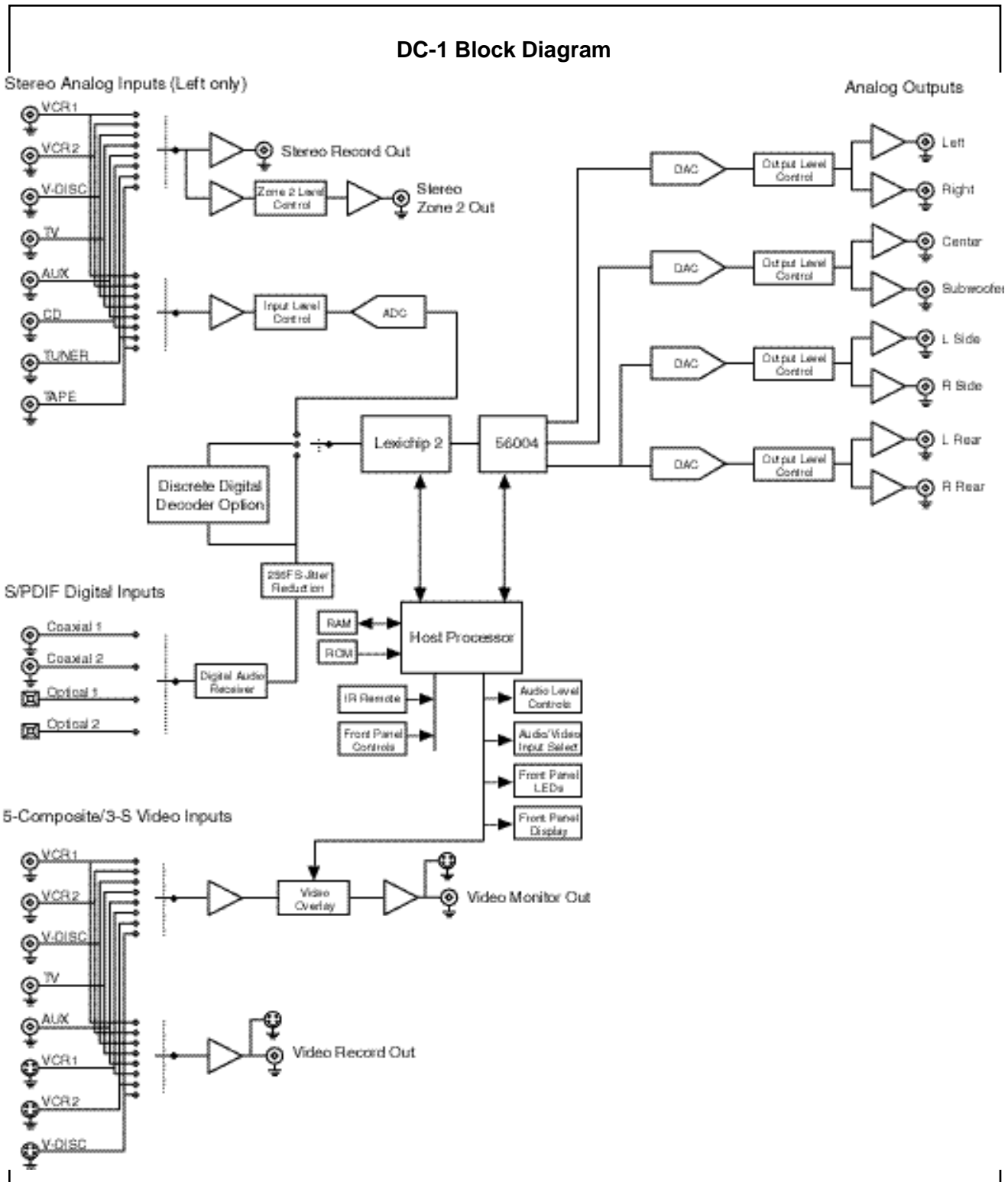

Controls and Indicators

The Front Panel

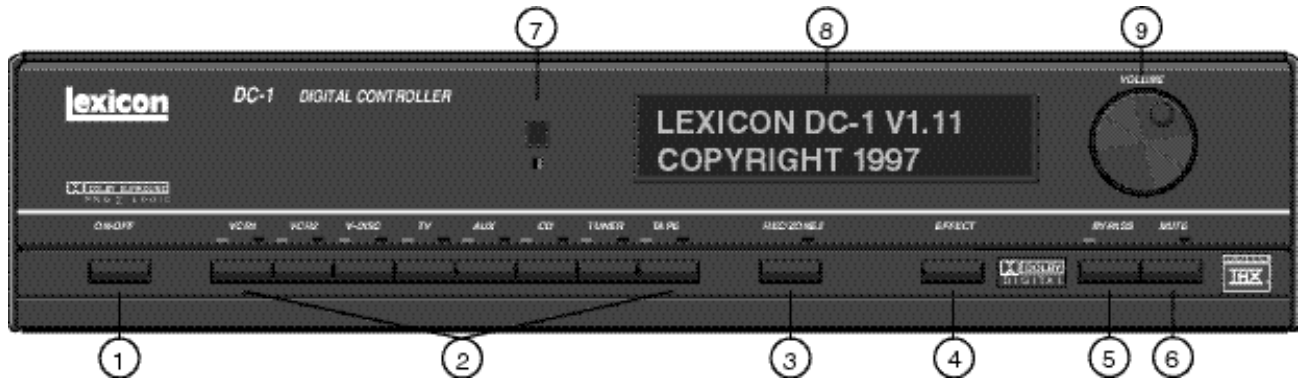

1. ON/OFF

ON/OFF alternately puts the DC-1 into and out of standby mode. Turning the DC-1 off with this button (or with the remote) deactivates the unit while leaving power to the signal processing circuitry to keep it at optimum operating temperature. Turning the DC-1 on with this button (or the remote) will restore the previous operating state.

2. Input Selection

Pressing any of these buttons (VCR1, VCR2, V DISC, TV, AUX, CD, TUNER, TAPE) selects the input at the corresponding rear panel connector as the current input selection and lights a green LED.

3. REC/ZONE 2

Selects and deselects the current input source for the RECORD and ZONE 2 outputs. When the REC/ZONE 2 function is engaged, the red LEDs are lit on the REC/ZONE 2 button and on the selected source input button. To change the REC/ZONE 2 source, press and hold down REC/ZONE 2 while pressing another input selector.

Some specific record sources are disallowed because of the potential for feedback loops. By default these are TAPE and VCR1. If a prohibited source is selected, an error message is displayed. The prohibited REC/ZONE 2 source choices can be changed in the Setup menu.

4. EFFECT

Displays the current effect, then steps through all available effects.

5. BYPASS

Toggles the selected effect on and off. The stereo analog or digital inputs are fed unprocessed to the front left, front right and subwoofer outputs while all other amplifier outputs are muted. A front panel LED will light yellow and screen messages indicate bypass is engaged.

6. MUTE

Attenuates all audio outputs except for RECORD or ZONE 2, lights a red LED, and displays a screen message to indicate mute is engaged. The attenuation level can be set in the Setup menu.

7. IR Receiver and LED

The IR receiver has an associated activity LED that lights green when valid IR signals are received, and an LED that lights red to indicate an overload condition at the inputs or within the DSP path. An IR input jack is available on the rear panel for a remote mounted IR receiver. The green activity LED remains illuminated when the unit is placed in Standby.

8. Display

A 2x20 backlit amber LCD displays the result of user action and the current status.

9. VOLUME

A position independent rotary encoder provides volume adjustment of all outputs, except for RECORD or ZONE 2. Screen displays show a volume bar and level in dB.

The Rear Panel

CAUTION: Never make or break any connections to the DC-1 with the rear-panel power ON. Make sure any associated amplifiers have been turned off for at least one minute before turning this master power switch on or off.

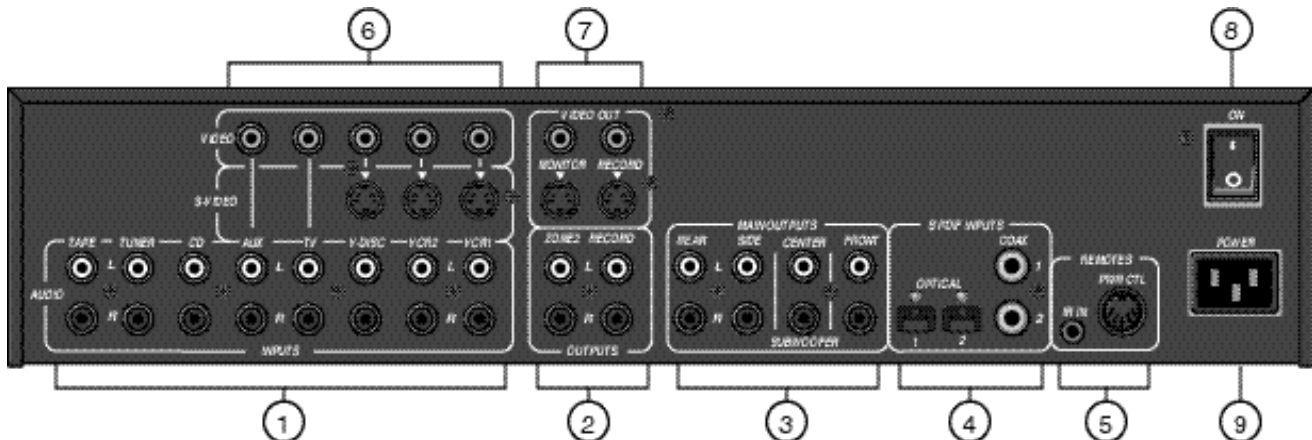
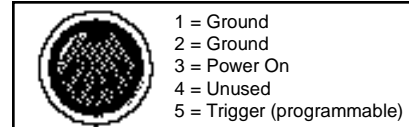

1. AUDIO INPUTS

Eight stereo analog audio inputs are switched with corresponding video inputs and fed to the Monitor outputs. Inputs are nominally labeled as originating from an audio tape player, tuner, CD player, an unspecified auxiliary source, a TV tuner, a Laser or Video Disc player, a secondary, and a primary VCR.

2. ZONE2 and RECORD

Each pair of stereo audio outputs supplies the same signal according to the record input selection. ZONE2 signal levels can be controlled independently for use with a second set of amplifiers and speakers in another room. ZONE2 can also be used as a second record output. When the output for ZONE2 is set to 0dB (unity gain), it has the same output level as RECORD. RECORD can be expanded to two outputs using standard Y-connectors. Both outputs are muted in standby.

3. MAIN OUTPUTS

Three stereo amplifier outputs are provided for front, side and rear speakers. Single monaural outputs are provided for the center speaker and the subwoofer. The audio outputs are muted in standby.

4. S/PDIF INPUTS

Two coaxial RCA connectors and two optical connectors are provided for digital audio in S/PDIF format at a 44.1kHz \pm 1000 ppm sample rate. The Dolby Digital version also accepts 48kHz signals.

5. REMOTES: IR IN, PWR CTL

The IR input is a miniature phone jack connector for input of modulated IR receiver data from an externally mounted IR LED receiver. Data is retransmitted by an IR LED mounted near the front panel IR receiver.

To prevent a feedback loop with the Record/Zone 2 outputs, VCR1 and TAPE are normally blocked from assignment as REC/ZONE 2 outputs. TAPE, TUNER, and CD default to VCR1 as a video input. Any input label and its default status can be changed in the Setup menu.

The Power Control port is a 5-Pin DIN connector. Pins 1 and 2 are ground, pin 3 is high when unit is on, low in standby or Off. High is indicated by either +12VDC or +5VDC, selectable via an internal jumper. (Factory configuration is +12V.) Pin 5 can be enabled (high) or disabled (low) for specific input selections in the Setup menu. See pinout diagram above.

6. VIDEO INPUTS

Five video input sources are provided. VCR1, VCR2 and V DISC, have both composite and S-video capabilities. (S-video is selected in preference to the composite signal.) AUX and TV accept composite only. Video inputs are selected with their corresponding audio inputs and fed to the selected monitor output jack. Record output jacks can be selected independently.

7. VIDEO OUTPUTS

RCA (composite) and S-video connectors are provided for monitor and record. If an S-video input is used, both S-video and composite are available at each output. If the video input is composite, only composite is available at each output. The monitor output incorporates the on-screen video overlay. Unless RECORD is enabled, the record output follows the monitor output selection without the on-screen display feature. Both outputs are blanked in standby.

8. Power On/Off

Master power switch disconnects the AC Mains. This switch is intended to be left On during regular use. Whenever cables are connected or disconnected, or when the unit is not going to be used for an extended period of time, this switch should be set to Off.

9. POWER

AC power connector: 3-wire, 10 Amp, IEC 320.

1. OFF and ON*

Separate OFF and ON buttons are provided for learning remotes, so that an automated key sequence does not require information regarding the current on/off status of the unit. OFF puts the unit into standby with audio muted, video blanked, the LCD and all LEDs, except for IR activity, turned off. The IR LED remains illuminated and the IR receiver remains active. The selected input, record status, current effect, volume and balance settings, and bypass state are saved.

2. EFFECT Up* and Down*

Display the current effect, then step through all available effects.

3. BYPASS*

Puts the front left/right and subwoofer outputs into stereo bypass. The stereo analog or digital inputs are fed unprocessed to the front left/right and subwoofer amplifier outputs while all other amplifier outputs are muted. A front panel LED will light yellow and screen messages indicate bypass is engaged.

4. MUTE*

Attenuates all audio outputs except for RECORD/ZONE 2, lights a red front panel LED, and displays a screen message. Attenuation level can be set in the Setup menu.

5. VOLUME Up* and Down*

Display the current volume setting, then adjust all outputs, except RECORD and ZONE 2. Screen displays show a volume bar and level in dB.

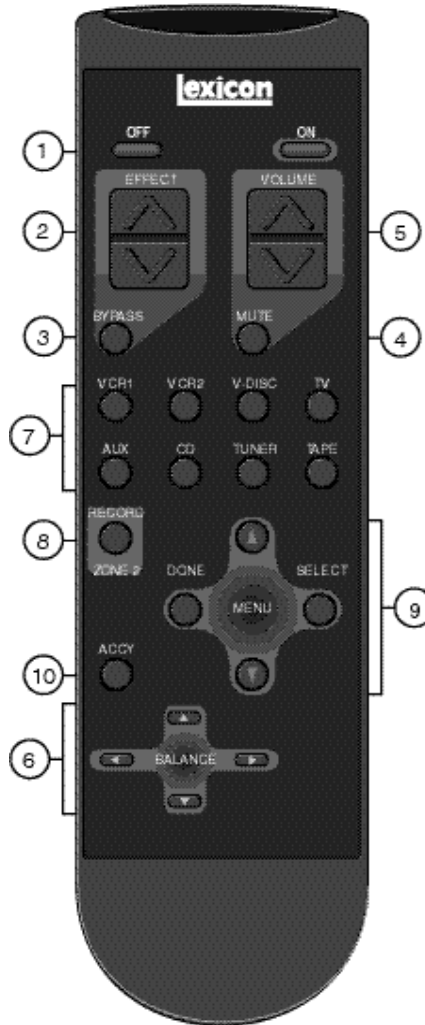

6. BALANCE Front*/Rear* and Left*/Right*

Display, then adjust the Front/Rear and Left/Right level balances. Front and Rear controls change the level balance between the front (Left, Center, Right) and rear (L&R Side, L&R Rear) outputs. Left and Right controls change the level balance between the left and right Front, Side and Rear outputs.

7. Input Selection*

Individual buttons select from 8 inputs and activate a corresponding green LED on the front panel. Depending on the Setup configuration, selection may also load a new effect.

The Remote Control

8. RECORD/ZONE 2

Selects and deselects the current input source for RECORD and ZONE 2 outputs. When the REC/ZONE 2 function is engaged, red LEDs are lit at the front panel REC/ZONE 2 button and at the selected source input button. To modify the ZONE 2 output without affecting other output levels, press and hold RECORD/ZONE 2, then adjust VOLUME.

Press MUTE while holding down RECORD/ZONE 2 to fully attenuate the ZONE 2 outputs. The ZONE 2 mute status will be indicated by a screen message. The attenuation level of the ZONE 2 output mute is not user adjustable. Repeat to cancel MUTE.

9. MENU*

SELECT, ▲, ▼ and DONE
Allow access to and adjustment of all displayed menu items. (Volume, Bypass, Balance and Mute functions remain active in menu mode.) MENU ▲ and ▼ step a display cursor through listed menu items. SELECT displays submenus, or chooses a menu item for adjustment. The ▲ and ▼ buttons alter the settings of selected parameters. DONE saves the current changes.

Press one of the EFFECT buttons, any Input Selector, RECORD/ZONE 2, or any BALANCE button to exit. Press OFF to exit the menu and enter standby.

10. ACCY

Provides accessory functions when pressed in conjunction with other remote buttons. (See following page.)

*In standby, pressing turns the unit on.

Remote Control ACCY Functions

Press and hold ACCY, then press DONE to activate a "You Are Here" mode which:

- Disables mute
- Sets volume to -30dB; sets Zone 2 volume to -20dB
- Centers Balance controls
- Loads the Pro Logic Effect
- Selects the VCR1 input; does not affect the Rec/Zone 2 input
- Activates On-Screen display with 2 second timeout
- Sets Remote Trigger ON
- Sets all tone controls to 0dB or OFF



To assign an effect to the input buttons, the original assignment must be cleared with the following procedure. Press and hold ACCY, then press BYPASS. Press the input button. The display should show EFFECT ASSIGNMENT CLEARED.

Assign the effect to the input button by scrolling to the desired effect, pressing and holding ACCY, then pressing the input button.

Connection

The DC-1 is a highly specialized signal processing computer and requires special care during installation to ensure optimum performance.

The DC-1 may be installed on a shelf or in a standard 19" equipment rack, using optional rack-mounting hardware available from Lexicon. Observe the following precautions:

- Select a dry, well-ventilated location out of direct sunlight.
- Do not stack the DC-1 directly above heat-producing equipment such as power amplifiers.
- Avoid placing the DC-1 near unshielded TV or FM antennas, cable TV decoders, or other receivers. The DC-1 may interfere with some FM tuners if it is placed immediately above or below them. Some products, particularly power amplifiers, may cause hum in the DC-1 if they are in close proximity.
- Make sure the DC-1 front panel IR receiver window is unobstructed. The remote control must be in line-of-sight to this receiver for proper operation. If line-of-sight is impractical, an infrared remote repeater can be used with the rear panel IR connector. The DC-1 may be placed in a glass-doored cabinet but smoked glass will make the front panel Liquid Crystal Display (LCD) difficult to read and will reduce the sensitivity of the IR receiver.

The DC-1 is designed to be connected to an uninterrupted AC power line in the same manner as a VCR or a television. We recommend the use of an AC line filter to protect against line surges, or the installation of a line conditioner to protect against under voltage (brownouts) as well as overvoltage conditions.

The DC-1 has a master power switch on the rear panel above the IEC standard AC power receptacle. This switch may be left ON continuously when the unit is in regular use. When the DC-1 will not be used for an extended period of time, or whenever you are connecting or disconnecting any cables to the unit, this switch should be turned OFF.

Connect the power cable to the DC-1, then plug the power cord into a wall outlet or into an unswitched outlet on a surge protector. Be sure that the power cord is firmly seated in the connector on the rear panel of the DC-1.

Location Considerations

AC Connections

Wiring Considerations

Audio/Video Cables

There is controversy over the audible effects of different types of interconnects. Good engineering practices have minimized the effect that cables might have on the inputs and outputs of the DC-1 — but feel free to evaluate different interconnects in your system. If you want to do some tweaking, be conscious of the mechanical stress from repeated insertion and overly tight connectors, and the possibly corrosive nature of some contact-enhancing fluids.

Note that the use of standard audio cables for video or digital audio applications may cause signal degradation, and is not recommended. For these connections, please use only cables that are designed for the application — these have different impedance characteristics than cables approved for analog audio applications.

Both audio and video cables should be kept as short as possible.

Speaker Connections

In general, speaker cables should be kept short, and low-impedance wire should be used throughout to assure efficient power transmission and avoid audible distortion. Recommended wire lengths are given in the table below. Although these examples can be used as a general guide, your system manuals should provide detailed information specific to your components.

Wire Lengths	
Length	AWG Size
up to 12 feet	16 gauge
up to 18 feet	14 gauge
up to 29 feet	12 gauge
up to 51 feet	10 gauge

Audio/Video Connections

Before making any connections, turn off ALL audio and video components, including individual power amplifiers. (Unplug any preamps and power amps that don't have power switches.)

The DC-1 is designed to function as the control center of the system, selecting inputs and controlling the volume of all speakers in the system. There are several ways to integrate the DC-1 into the system, but they basically fall into two categories: those where the DC-1 is connected directly to all of the amplifiers in the room, and those where the DC-1 is connected into a tape or signal processor loop of a preamp or receiver.

You may choose to connect the DC-1 in the tape monitor, or external processor loop of a preamp, allowing you to completely bypass the DC-1. This, however, will make the system somewhat more complicated to operate, and adds a gain stage (the preamp) that is not necessary.

Connecting the
DC-1 as a preamp

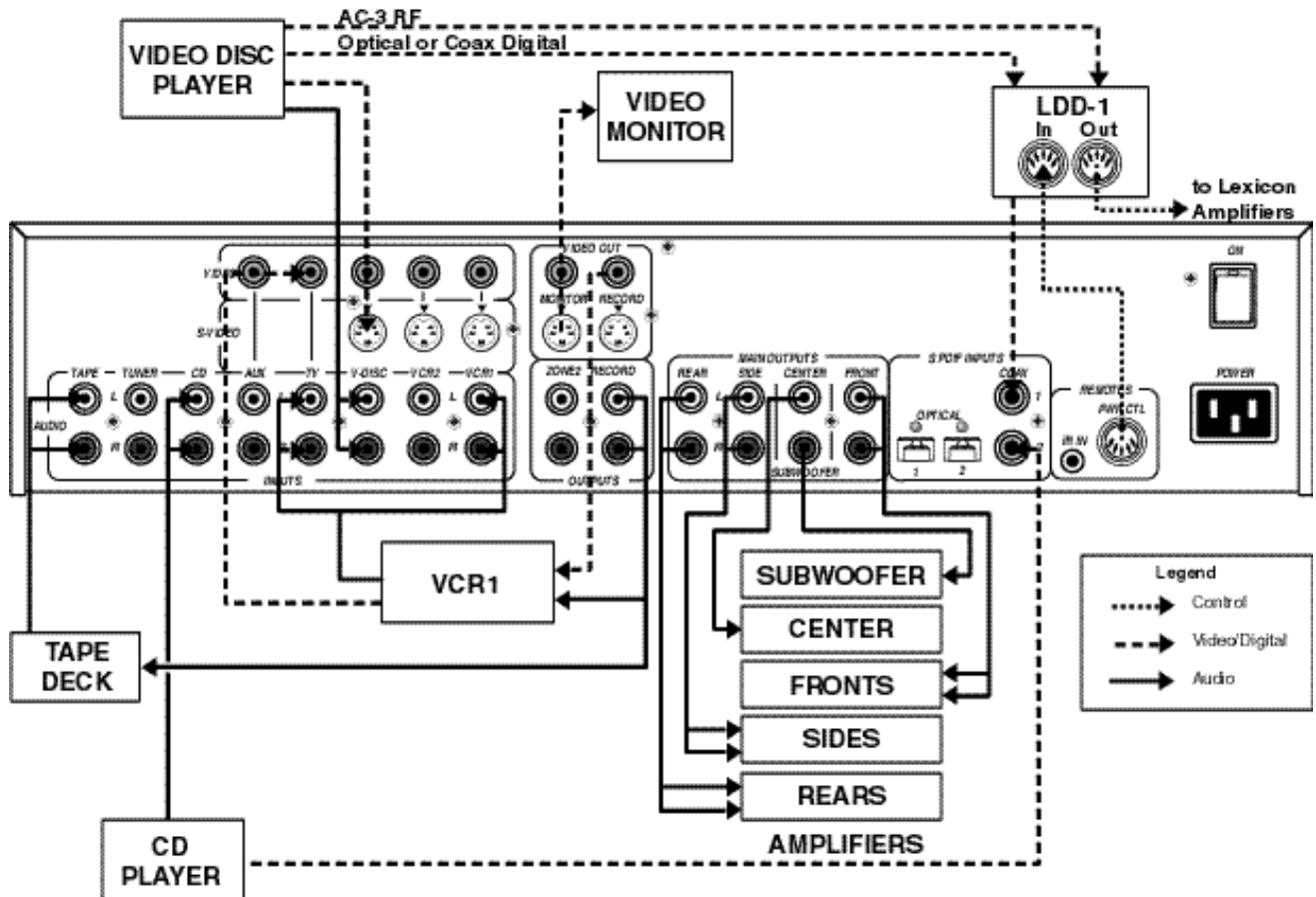

Input sources can each be connected directly to the DC-1 inputs. A typical system might use the TV, VCR1, V-DISC and CD and TUNER (output through a preamp). Since TAPE, TUNER and CD are audio only, the video output will default to the video signal from VCR 1. This feature allows TV or other video source viewing while different audio is playing, but can be defeated in the Setup menu.

Connect your main stereo amplifier to the DC-1 FRONT outputs. Connect any additional amplifier/speaker combinations to the remaining outputs on the DC-1: side amplifiers to the SIDE outputs, rear amplifiers to the REAR outputs, center-channel amplifier to the CENTER output and the subwoofer amp to the SUBWOOFER output. If you are using THX-type dipolar surround speakers, the amplifier driving them should be connected to the DC-1 SIDE outputs.

Whenever possible, connect both analog and digital outputs of digital sources. This enables use of a digital input for the main zone, and the corresponding analog input for the Record/Zone 2 outputs.

Note the use of Y-connectors to feed the DC-1 Record output to both the VCR and the tape deck. In this example, Y-connectors are also used to direct the VCR audio output to both the TV and VCR inputs on the DC-1, so that the VCR can also be used as a TV tuner.

Video Connections

The DC-1 has five composite video inputs, three of which also support S-Video. Connection to an S-Video input will override the composite signal connected via the RCA-type connector. Note that an S-Video input will be output on both the composite and S-Video outputs. The reverse is not true — composite input signals will not be output as S-Video.

You can assign any video source to any (or all) of the eight DC-1 inputs via the Input Configuration submenu of the Setup menu. This can be very useful in systems which use a VCR as the tuner for TV viewing, as the video feed from the VCR can be assigned to both the VCR and TV inputs. The VCR's audio signals can be fed to both inputs with Y-connectors. (Do not use Y-connectors on video signals.) This allows the audio and video signals from the VCR to be used for both TV and VCR viewing.

You can also assign any video source to audio-only sources such as an AM/FM tuner, to enjoy music from another source while viewing a video source.

It is important to remember that the impedance characteristics of composite video and digital audio are different from analog audio. You should only use cables specifically designed for video and digital audio. Consult your dealer for recommendations.

Digital Audio Connections

The digital inputs can be set up to be selected with any (or all) of the eight inputs via the Setup menu. Two coaxial (RCA) and two optical (TOSLINK™) inputs are provided. Using the digital inputs will always provide better performance.

The Base and THX versions of the DC-1 will accept digital signals sampled at 44.1kHz. The Dolby Digital version of the DC-1 accepts sample rates of either 44.1 or 48kHz.

When using a 48kHz digital connection from a source (DSS, DAT), the following effects are available:

THX Cinema	Two Channel
Logic 7	Music Logic
Pro Logic	TV Matrix
Music Surround	

Note that current "AC-3 ready" laser disc and LD/DVD players do not output a single digital audio bitstream that incorporates the Dolby Digital (AC-3) data. Instead, the AC-3 data from laser discs is output on a separate RCA jack in Radio Frequency (RF) form. To maintain the exceptional performance of the DC-1, an outboard demodulator is required to turn this RF signal back into a digital bitstream. By performing the necessary demodulation outside the DC-1, the potential for RF interference is eliminated. The Lexicon LDD-1 is an excellent example of one such device. An outboard demodulator is not required for DVD players.

For recording purposes, it is advisable to connect both the analog and digital outputs of your digital sources, as the record outputs do not have dedicated D/A converters. It is possible, however, to use the internal D/A converters in the DC-1 for recording. Select the input you want to record, then press the REC/ZONE 2 button until red LEDs above the REC/ZONE 2 and the corresponding input button light.

If a digital audio input is selected without a valid signal, or if a digital error which affects audio performance is detected, all audio outputs are muted and an error message is displayed. The associated input on the front panel will display a blinking red LED while the error condition persists. When valid data is restored, the error message is cleared and the unit returns to normal operation. The display indicates the sample rate and AC-3 (if appropriate) when a valid digital signal is being received. Whenever Emphasis is detected within the incoming digital audio channel status bits, de-emphasis is automatically applied.

"AC-3 Ready" Laser Disc and LD/DVD Players

Recording a Digital Source Using the DC-1 D/A Converter

NOTE: Effect Bypass is engaged when DIGITAL is selected for REC/ZONE 2 in the Input Configuration menu.

Digital Input Status Detection

RECORD/ZONE 2 Operation

The DC-1 is designed to be the control center of any system. As such, there are separate outputs for easy integration of external recording devices as well as additional “zones” in multi-room installations.

The Record and Zone 2 outputs on the DC-1 are wired in parallel so that the input selection will always be the same for both. For example, if the CD input is selected for Record, the CD input is also output to Zone 2. The only difference between the Record and Zone 2 outputs is that Zone 2 has its own volume control, while the Record output level is fixed. When the DC-1 is powered up, the Zone 2 output is muted.

The DC-1 normally assigns any input selected for the Main zone (indicated by a lit green LED at the front panel input button), to the Record and Zone 2 outputs as well. Although this will be appropriate for installations where the same input is desired for all three outputs, a different input can easily be assigned to the Record and Zone 2 outputs. This allows any input to be selected for the Main zone, while leaving the Record/Zone 2 outputs unaffected. The procedure for assigning these outputs is described below.

To assign the current input to the Record/Zone 2 outputs, press and hold REC/ZONE 2 until the red LEDs at the appropriate front panel input button and at the front panel REC/ZONE 2 button light.

To clear the assignment, press and hold REC/ZONE 2 until the LEDs turn off.

For Example:

VCR2 is selected for the Main output (and its front panel green LED is lit). Pressing and holding down the remote control or front panel REC/ZONE 2 button will light the red LED above the front panel REC/ZONE 2 button as well as the red LED above the currently selected input (VCR2).

You have now assigned VCR2 to the Record/Zone 2 outputs. In this state, new input selections will not affect the Record/Zone 2 outputs.

Now, suppose you want to change the Record/Zone 2 assignment to the CD input. To do this, press CD and press and hold REC/ZONE 2 until the red front panel LEDs turn off.

You have now cleared the previous Record/Zone 2 assignment. To assign CD to the Record/Zone 2 outputs, press and hold REC/ZONE 2 again. The red LED above the front panel REC/ZONE 2 button as well as the red LED above the CD input will light.

As protection against feedback, the TAPE and VCR1 inputs are normally blocked from being used as sources for the Record and Zone 2 outputs. This default condition can be changed in the Input Configuration menu as follows.

Use MENU ▲ and ▼ to select REC/ZONE 2, then press SELECT. The MENU ▲ and ▼ buttons will select ANALOG, DIGITAL, or BLOCKED as the state of the input.

ANALOG allows maximum flexibility by utilizing both the digital and analog connections of a digital source component (provided both are connected). The DC-1 processes the digital input signal for the main zone, and simultaneously routes the analog input signal to the Record and Zone 2 outputs. Since no D/A converters are necessary for the analog input signal, the functionality in the Main zone is not compromised.

DIGITAL routes the digital signal, assigned to the input, to the DC-1's 20-bit Digital to Analog (D/A) converters. After conversion, the signal is sent to the Record and Zone 2 outputs. As this setup bypasses the D/A converters in the source component, and utilizes the 20-bit D/A converters in the DC-1, sound quality can be dramatically improved when recording or listening in Zone 2. This setup automatically engages Effect Bypass in the main zone.

BLOCKED simply blocks the input from being sent to the Record and Zone 2 outputs. This prevents feedback from occurring with devices that have both an input and output attached to the DC-1 (Tape deck, VCR, etc.).

NOTE: Removing the block from any input which has both an input and output attached may cause damaging feedback.
--

The remote control can be placed into an exclusive Record/Zone 2 control mode during normal operation by holding down ACCY and pressing RECORD/ZONE 2. This will display the message:

**ZONE 2 IR REMOTE
MODE ENABLED**

In this mode, the Volume, Mute, Input selection and L/R Balance controls will directly control the Zone 2 outputs with no effect on the Main outputs. Pressing any other keys will display the message:

**ZONE 2 MODE ENABLED
KEY INVALID**

To exit Zone 2 Remote mode and return the remote control to normal operation, press and hold ACCY, then press SELECT. The message:

**NORMAL IR REMOTE
MODE ENABLED**

will be displayed to confirm that normal operation has been restored.

Zone 2 Remote Control

Exclusive Zone 2 Control

The DC-1 can also be used as an exclusive Zone 2 controller, allowing remote use of the system while the local room (the room in which the DC-1 is located) remains muted. To use the DC-1 in this manner, turn on the DC-1 by pressing the RECORD/ZONE 2 key on the remote. The unit will power up with the System Mute and Effect Bypass activated. The remote will default to Zone 2 IR Remote mode as described above, with Volume, Mute, Input Selection and L/R Balance controlling only the Record and Zone 2 outputs. To return to normal operation, simply press OFF, then ON.

Digital audio inputs can be selected for the Record/Zone 2 outputs under the following conditions:

- The digital input must be assigned to an input via the Setup: Input Configuration menu.
- The input must have REC/ZONE 2 set to DIGITAL. (TAPE and VCR1 are normally "BLOCKED", but can be changed in the Input Configuration menu.)
- The input must be selected for Main outputs.

System Configuration

Although the DC-1 memory is cleared before it leaves the factory, it is good practice to reset the unit before programming it. The following procedure resets the unit to factory condition:

Turn the DC-1 OFF with either the front panel switch or the remote. Turn the unit back ON and immediately press and hold the BYPASS button on the remote. (Make sure you do not block the infrared receiver on the DC-1 front panel.) The display will read:

FACTORY PRESETS MENU
EXIT
RESTORE DEFAULTS

Use MENU ▲ or ▼ to highlight RESTORE DEFAULTS, then press SELECT. This will clear and reload all preset effects and all factory settings of Volume, Balance, Contrast, Configuration, etc. When the message FACTORY DEFAULTS RESTORED is displayed, press DONE to return to normal operation.

Depending on the location of the DC-1 in your room, you may need to adjust the front panel display for optimum viewing. To adjust this display, press the MENU ▲, ▼ or SELECT buttons on the Remote to enter the Main Menu. Press MENU ▼ twice to select DISPLAY ADJUST.

Press SELECT to highlight the Display Adjust Menu. Press MENU ▼ to select FRONT PANEL DISPLAY.

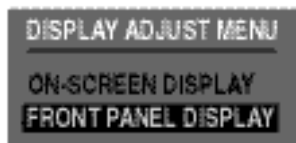

Display Adjustment



To adjust contrast, use SELECT to highlight CONTRAST ADJUSTMENT, and MENU ▲ or ▼ to set the contrast of the display to its maximum as seen from your listening position. Press DONE twice to return to the main menu.

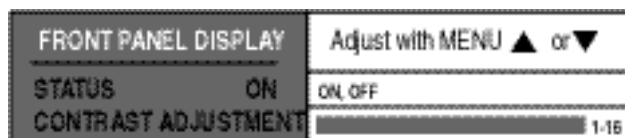

If you want to turn the front panel display off, use SELECT to highlight STATUS, then use MENU ▲ or ▼ to select OFF. Press DONE twice to return to the main menu.

The Video On-Screen Display



In addition to the front-panel display, the DC-1 contains a character generator for a video overlay display on monitors. Since the on-screen display is capable of showing the full menu of options available at any point, calibration of the system is faster and easier if the DC-1-video output is connected to a video input on a video monitor. This display will also show any dynamic adjustments to controls such as volume, contrast, etc.

Adjustments to the on-screen display are made from the Display Adjust menu. To display this menu, press the MENU ▲, ▼ or SELECT buttons on the Remote to enter the Main Menu. Press MENU ▼ twice to select DISPLAY ADJUST.

Press SELECT to enter the Display Adjust menu. Press SELECT to open the On-Screen Display menu.



ON-SCREEN DISPLAY		Adjust with MENU ▲ or ▼
STATUS	2 SECONDS	ALWAYS ON, 2 SECONDS, ALWAYS OFF
POSITION	TOP	TOP, CENTER, BOTTOM
FORMAT	NTSC	NTSC, PAL, SECAM
COLOR	ENABLED	ENABLED, DISABLED

This menu allows you to choose the position and duration of items displayed on-screen during normal operation, as well as the options of color or black and white display and conformance to local broadcast format.

Adjusting the position allows you to move the DC-1 display items to a location where they will not interfere with any other video overlays your system may generate.

Video Input Selection and the On-Screen Display

When using the Video Monitor output with the On-Screen Display, the DC-1 automatically puts up a blue or grey background when no video signal is present.

Occasionally, an incoming video signal may be so weak that it is recognized as essentially no signal, triggering the background overlay. If this occurs, simply reselect the input.

The STATUS option allows you to choose to have the on-screen display always off, always on, or on for a two-second duration. Note that if you choose to have the display "time out", this will not affect the display of the main menu. Note also that parameter changes will still be performed when you make adjustments with MENU ▲ or ▼, even if the display is inactive. If you choose ALWAYS OFF, you will not be able to use the video overlay, and even setup will have to be done using only the front-panel display.

COLOR allows you to have the on-screen display presented in monochrome or color. FORMAT allows you to select NTSC, PAL or SECAM formats. (Note that SECAM format is available only in monochrome).

Press DONE twice to return to the main menu.

The DC-1 Setup menu allows you to customize the system defaults to suit a wide range of possible system configurations. Each of the five entries in the Setup menu will be discussed in detail in this section.

Select SETUP from the main menu to display the Setup menu. Use MENU ▲ and ▼ to step the cursor through the Setup menu selections. Once an item is highlighted, pressing SELECT will display a sub-menu for that item. With the sub-menu displayed, MENU ▲ and ▼ once again highlight menu items. Press SELECT, then use MENU ▲ and ▼ to adjust the settings of any item over its available range. Press DONE to exit any sub-menu; press DONE again to return to the Setup menu.

The DC-1 has eight analog stereo audio inputs, each of which can be associated with any of the five video and four digital audio inputs. Selecting Input Configuration from the Setup menu displays a sub-menu which lists these inputs and allows you to select them individually for adjustment. Each input has an identical parameter sub-menu. VCR 1 is shown below as an example.

INPUT CONFIG	VCR1	Adjust with MENU ▲ or ▼
GAIN	AUTO	AUTO On/Off or MANUAL -18 to +12dB
NAME	VCR1	RESTORE DEFAULT or EDIT NAME
EFFECT	THX CINEMA	USE LAST EFFECT or any non-AC-3 Effect
AC-3 FX	USE LAST	USE LAST EFFECT or any AC-3 Effect
DIGITAL	NONE	Sources: NONE, COAX 1-2, OPTICAL 1-2
VIDEO	VCR1	Sources: NONE, VCR 1-2, V-DISC, TV, AUX
REC/ZON	BLOCKED	Record Output: Analog, Digital or Blocked
TRIGGER	ENABLED	External Trigger Output: Enable/Disable

For optimal performance, the unit must be driven to its full input level without overloading. Despite industry attempts at standardization, different sources have a wide range of output levels. To compensate for this, each of the eight DC-1 analog inputs can be assigned a different input gain, assuring optimum performance and consistent volume, regardless of the source. For use with a calibration tone, the Dolby reference point is indicated by an enlarged tick mark on the on-screen level meters.

The DC-1 has an auto level function which monitors the analog input level and automatically optimizes the input gain (AUTO). When activated, this feature controls the input gain. If the signal level is too high and causes an input overload, input gain is automatically decreased to a point which does not cause an overload. When the signal level remains low (>12dB below clipping for 2.5 minutes), the input gain is incremented in 1dB steps to maximize dynamic range.

System Setup



Input Configuration

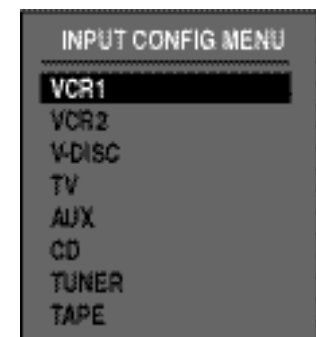

Input Gain

Although you are given the option of defeating the auto level system by selecting MANUAL, this is not recommended. When MANUAL is selected, the display shows the last auto level setting. (If the auto level feature has not been used, the display shows the last manually entered level.) The auto level setting indicates the optimum input level value as determined by the unit. The MENU ▲ and ▼ buttons increase or decrease the input gain in 1dB increments for the selected input over a range of -18dB to +12 dB. The setting is displayed in dB along with horizontal bargraph meters on the on-screen display to indicate incoming signal level.

Input Level Meters

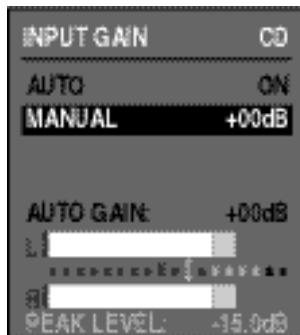

The input level meters are displayed when you select the GAIN parameter for an active input which has been selected in the Setup menu.

When GAIN is selected, two on-screen horizontal bar meters display peak incoming signal level. The highest peak level is shown in dB in a separate text line, and as an arrow in the the meter display. White, yellow and red sections of the bar meter show increasing levels. The white portion is shown in 3dB increments, the yellow and red portions are shown in 1.5dB increments. An enlarged block at -21dB indicates the reference level used with a Dolby calibration tone source.

The peak level display can be refreshed by pressing DONE to exit, then pressing SELECT to return to the display.

Input Name

Each input has an associated name which is displayed during normal operation whenever the input is selected. The default names correspond to the labels on the DC-1 remote control and the front and rear panels. These names can be customized to more accurately reflect your system configuration.

To assign a new name (up to 8 characters) for an input, select NAME from the Input Configuration menu, and EDIT INPUT NAME from the sub-menu. The display will show the current name with a cursor marking the character position to be modified. Use the MENU ▲ and ▼ buttons to select a new character for that position, and SELECT to move the cursor to another position. Press DONE twice to return to the Input Configuration menu.

Restore Input Name

This control allows you to restore the factory name for the currently selected input. Pressing SELECT displays the message PRESS SELECT TO RESTORE INPUT NAME. Pressing SELECT again restores the name and exits to the Input Configuration menu.

Input Effect Assignment

The DC-1 has the ability to load an effect whenever an input is chosen. For example, if you primarily listen to CD's with the CONCERT HALL effect, the DC-1 can be set to load this effect when the CD input is chosen. (You can listen to any effect using the EFFECT button on the front panel or the remote control.) If you select USE LAST, the DC-1 will load the last effect used for the selected input. Any effect can be assigned to any or all of the eight inputs.

The Dolby Digital version of the DC-1 will automatically switch to an AC-3 effect whenever AC-3 encoded material is detected at the input. This allows one input to be used for different formats. For example, in the factory default state, the V-DISC input will automatically load the THX 5.1 effect when an AC-3 signal is present, and the THX CINEMA effect when a non-AC-3 signal is present. The default selections for input effect assignment are shown below for all three versions of the DC-1.

	Base Effect	THX Effect	Dolby Digital	
			non AC-3 Effect	AC-3 Effect
VCR1	PRO LOGIC	THX CINEMA	THX CINEMA	USE LAST
VCR2	PRO LOGIC	PRO LOGIC	PRO LOGIC	USE LAST
V-DISC	PRO LOGIC	THX CINEMA	THX CINEMA	THX 5.1
TV	TV MATRIX	TV MATRIX	TV MATRIX	USE LAST
AUX	PARTY	PARTY	PARTY	USE LAST
CD	MUSIC LOGIC	MUSIC SURROUND	MUSIC SURROUND	USE LAST
TUNER	NIGHTCLUB	CONCERT HALL	CONCERT HALL	USE LAST
TAPE	CHURCH	CHURCH	CHURCH	USE LAST

* V-DISC is the only input which has an AC-3 effect assigned as a factory default.

The DC-1 remote control can be set up for direct access of as many as eight effects. To assign these, first press the EFFECT button on the remote to scroll to the effect you want to assign. Hold down the ACCY button on the remote and press any one of the eight input buttons. The display will confirm your selection.

**EFFECT
ASSIGNED TO ACCY+ INPUT KEY**

To directly access this effect (regardless of input), simply hold down the ACCY button and press the corresponding input button.

To clear an effect from an INPUT button, press and hold ACCY. Press BYPASS, then press the appropriate input button. The display will show:

**EFFECT ASSIGNMENT
CLEARED**

Digital Audio Input Assignment

NOTE: Some older laser discs do not contain digital audio tracks. You will not hear audio when playing these discs if you have selected a digital input as the V-DISC source.

The four DC-1 digital audio inputs include two coaxial (RCA) and two optical connectors (TOSLINK™). For maximum configuration flexibility, each of the four digital inputs can be assigned to any (or all) of the source selections.

Video Input Assignment

NOTE: S-Video input signals will be output on both the composite and S-Video jacks. However, if you are only connecting to the monitor via the S-Video output, composite video input sources will not be displayed.

The inputs labeled VCR1, VCR2, V-DISC, TV, and AUX normally have corresponding video inputs. The inputs labeled CD, TUNER, and TAPE do not have associated video inputs, and default to the video input VCR1. For maximum configuration flexibility, each of the five video inputs can be assigned to a different source selector. If the assigned video input has both S-Video and composite jacks, the S-video signal takes priority whenever a cable is plugged into the appropriate S-video connector.

Record/Zone2 Output Blocking

This feature provides feedback protection when selecting a record source. BLOCKED input sources cannot be selected for the record outputs, thus disabling the record function. Normally, the record outputs are disabled for only the TAPE and VCR1 inputs. This sub-menu allows you to alter these defaults for other configurations.

ANALOG allows maximum flexibility by utilizing both the digital and analog connections of a digital source component (provided both are attached). The DC-1 processes the digital input signal for the main zone, and simultaneously routes the analog input signal to the Record and Zone 2 outputs. Since no D/A converters are necessary for the analog input signal, the functionality in the Main zone is not compromised.

DIGITAL routes the digital signal, assigned to the input, to the DC-1's 20-bit Digital to Analog (D/A) converters. After conversion, the signal is sent to the Record and Zone 2 outputs. As this setup bypasses the D/A converters in the source component, and utilizes the 20-bit D/A converters in the DC-1, sound quality can be dramatically improved when recording or listening in Zone 2. This setup automatically engages Effect Bypass.

BLOCKED simply blocks the input from being sent to the Record and Zone 2 outputs. This prevents feedback from occurring with devices that have both an input and output attached to the DC-1 (Tape, VCR, etc.).

Remote Trigger Assignment

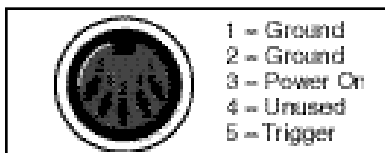

This menu item assigns the status for the remote trigger that appears on pin 5 of the Power Control DIN jack on the DC-1 rear panel. +12VDC is provided for controlling ancillary equipment or functions. This signal can be ENABLED or DISABLED for the selected input. The factory default is ENABLED (high) for A/V inputs and DISABLED (low) for audio only inputs. (+5VDC is available via internal jumper. Contact your dealer or Lexicon Customer Service to perform this change.)

The Speaker Configuration menu allows a wide range of choices in speaker placement and room setups to provide optimal performance in almost any room with virtually any speaker system. The menu allows you to set the system for performance with center, sides, rear or subwoofer speakers. An adjustable crossover is provided for systems with small center speakers, and an adjustable lowpass filter is available for the subwoofer, as well as a complementary highpass filter for all other speakers.

Press SELECT to access the selections for any highlighted menu item.

SPEAKER CONFIG MENU		Adjust with MENU ▲ or ▼
FRONT L/R	SMALL	LARGE, SMALL
CENTER	SMALL	LARGE, SMALL, NONE
SIDES	DIPOLE SMALL	L.G or SM STD, L.G or SM DIPOLE, NONE
REARS	SMALL	TWO, ONE, NONE or L.G, SM, NONE
SUBWFR	YES	YES, NO

Select LARGE for full-range front speakers to deliver full frequency response to the front outputs. Selecting SMALL activates a 12dB per octave highpass filter and automatically routes low frequency information to the subwoofer output. Choices of 80, 100 and 120 Hz are available for the -3dB point. The 80Hz filter should be used if you are using THX-certified speakers. You may also want to turn this control ON if you are using small satellite, or in-wall speakers. Consult your dealer to determine their low frequency capability.

Systems that utilize a full-range center speaker should select LARGE to direct center information to the center output with a full frequency response. Select SMALL for installations where the center speaker is smaller than the two main stereo speakers. This will automatically engage the Bass Split feature which takes the low frequency content from the center, and distributes it to the left and right front speakers, reducing the risk of damage to a small center speaker without loss of bass information. When SMALL is highlighted, press SELECT to display and adjust the crossover point for the low frequency redistribution. Available crossover points are: 80, 100, and 120Hz. Press DONE to return to the Speaker Configuration menu.

Setting the Speaker Configuration



Front L/R

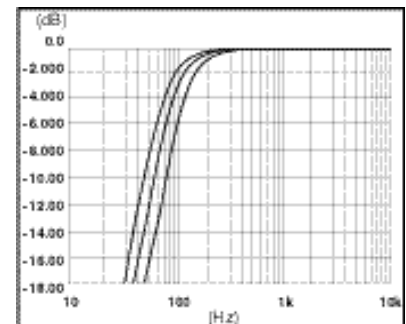

The high pass filter attenuates low frequencies at 12dB per octave. The values given are for the -3dB point.

Center

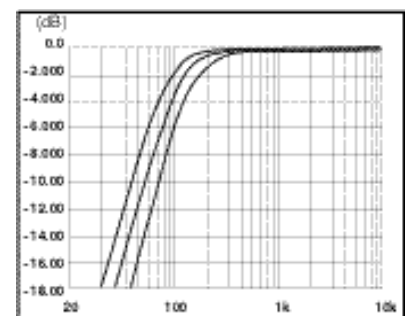

Bass Split rolls off frequencies at 12dB per octave. The values given are at the -3dB point of attenuation from the center speaker.

Sides This menu sets the system for your particular side speaker configuration. Systems with side speakers should be designated as STANDARD (LARGE or SMALL) or DIPOLE (LARGE or SMALL). DIPOLE indicates a THX speaker configuration, and causes the unit to mute the rear outputs when either THX effect is used. When STANDARD SMALL or DIPOLE SMALL is highlighted, press SELECT to display and adjust the highpass filter for the side outputs. Choices are: OFF, 80, 100 or 120Hz.

Selecting NONE mutes the side outputs and disables any effect parameters related to side speakers.

Rears In the Dolby Digital version of the DC-1, the active selections are LARGE and SMALL. Systems that utilize full-range rear speakers should select LARGE to direct a full-range signal to them. SMALL should be selected when filtering is desired. (Off, 80, 100 and 120Hz are available as settings for the -3dB point).

Selecting NONE mutes the rear outputs and disables any effect parameters related to rear speakers.

Subwoofer Output

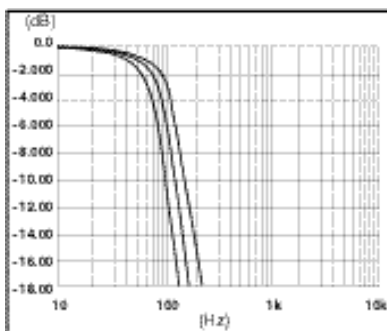

Subwoofer Frequency Response

Use of the subwoofer output is specified here. Selecting YES, then pressing SELECT allows you to display and adjust the crossover frequency for the subwoofer output. The subwoofer output is created by summing the front, left, center and right outputs, followed by a 24dB/octave lowpass filter. For 5.1 effects in the Dolby Digital version, the two surround channels and the LFE channel are also summed. Both the summing and filtering are performed in the digital domain. You can select three different crossover points (80, 100 or 120Hz) for the subwoofer. Although you can also elect to bypass the crossover and run a full range output if your subwoofer has an internal crossover, it is generally best to use the crossover in the DC-1.

NO mutes the subwoofer output and disables the Subwoofer Level parameter.

When DC-1 input and output levels are set properly, the entire system will be calibrated to play films at the level intended by the director. Setting the output levels is easy, particularly if a Sound Pressure Level (SPL) meter is used. Using an external source, such as the "Video Essentials" laser disc (ID3487ISF) or "The Surround Spectacular" disc from Delos (DE-3179), or the DC-1's internally generated calibration signal, adjust the level of each output to the same relative level.

Setting Output Levels



OUTPUT LEVELS MENU	Adjust with MENU ▲ or ▼
INTERNAL NOISE TEST	Noise signal sent sequentially to all speakers
EXTERNAL NOISE TEST	Pro Logic effect w/current input as source
SUB PK LIMITER +25dB	-5 to +35 dB
MUTE LEVEL -30dB	-10dB, -20dB, -30dB, -40dB, FULL MUTE
PWR-ON VOL -30dB	LAST LVL, -80 to +12dB
ZONE 2 VOLUME -30dB	LAST LVL, -80 to +12dB

Select INTERNAL NOISE TEST or EXTERNAL NOISE TEST from the Output Levels menu. The INTERNAL NOISE TEST automatically disconnects all audio and video inputs, disables any EQ functions, centers the Balance controls, loads the Pro Logic effect, and sets the system volume to 0dB. The test signal circles the room according to the speaker configuration you have defined in the Speaker Configuration menu. For a full complement of speakers, the order is: Left Front, Center, Right Front, Right Side, Left Side, Subwoofer, Right Rear, Left Rear. The EXTERNAL NOISE TEST loads the Pro Logic or Dolby Digital effect and uses the signal from the currently selected input for calibration.

Once a test source is selected, a sub-menu showing each output level is displayed. Use the MENU ▲ and ▼ buttons to highlight an output for adjustment. Press SELECT to stop the cycling of the noise signal, then use MENU ▲ and ▼ to adjust the selected output level in precise 0.5dB increments from -10dB to +10dB.

OUTPUT LEVELS MENU	Adjust with MENU ▲ or ▼
INTERNAL NOISE TEST	-10dB to +10dB
EXTERNAL NOISE TEST	
*These selections will not be active if "NONE" is selected in the Speaker Configuration menu.	
LEFT FRONT	
CENTER	
RIGHT FRONT	
RIGHT SIDE	
LEFT SIDE	
SUBWOOFER	
RIGHT REAR	
LEFT REAR	

NOTE: If any of the amplifiers in your system have gain (volume) controls, their level settings will affect the balance of the DC-1 outputs. Generally, the gain controls of these amps should be set at or near maximum. You should record the values of these controls for later reference.

Using a Sound Pressure Level Meter such as Radio Shack model 33-2050 or 33-2055, set the weighting to *C* and the response to *Slow*. Adjust all output levels to achieve 75dB at the listening position.

In the absence of an SPL meter, it is possible to set the output level by ear. Use the internal noise generator in the DC-1 to adjust all volumes to be the same as they cycle around the various speakers. Depending on timbre variations between your speakers, this may be difficult to judge — get as close as you can. The system should be reasonably well balanced, although not actually calibrated for precise playback and level matching. With the system volume at 0dB, the internal noise source should be at the same level at which film dialog sounds comfortable.

**Subwoofer Peak Limiter
(Dolby Digital version)**

Dolby AC-3 encoded soundtracks can produce low frequency peaks that are 15dB higher than those in matrixed Dolby Surround decoding. These higher levels may be troublesome in the home listening environment, either because they disturb non-listeners in nearby rooms, or because of the inability of the subwoofer and its associated amplifier to reproduce these levels without clipping.

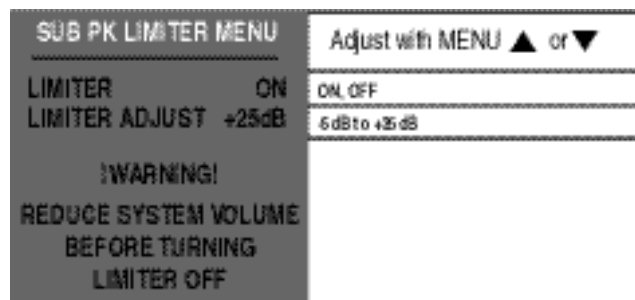

The Dolby Digital version of the DC-1 provides a Subwoofer Peak Limiter that prevents the subwoofer signal level from exceeding a preset value. The limiter is factory preset to a level of +25dB. This setting can be changed within the limiter's operating range of -5dB to +35dB, with -5dB providing maximum limiting.

To turn off the limiter or to change its setting, select the SUB PK LIMITER parameter in the Output Levels menu.

If you want to turn the limiter off, first turn the system volume down in order to prevent the subwoofer from overloading.

Press MENU ▼ to select LIMITER, then press SELECT. Press MENU ▼ to select OFF. Press DONE twice to return to the Output Levels menu. While readjusting the system volume back to a comfortable listening level, check to be sure the subwoofer or its amplifier is not overloading on passages with low frequency effects.

Selecting **LIMITER ADJUST** in the Sub Peak Limiter menu invokes a calibration routine for setting the optimal peak level for your installation. Pressing **SELECT** routes low frequency calibration noise to the subwoofer output of the DC-1. A two-line display indicates the **LIMITER LEVEL** setting in dB on the top line with a bar at the bottom to indicate relative noise level. Press **MENU ▲** and **▼** to adjust the noise level to the highest level that your equipment can reproduce without overload.

Be sure the limiter is set to **ON** before exiting. Press **DONE** to exit and automatically set the limiter to the level you have selected.

Keep in mind that the Sub Peak Limiter is separate from the Subwoofer level control in the Effect Adjust menus — one setting does not affect the other.

This menu allows you to set the level of attenuation used whenever the DC-1 **MUTE** function is engaged. In the Output Levels menu, attenuation levels of -10dB, -20dB, -30dB, -40dB, and **FULL** are available.

Mute Level

This control in the Output Levels menu allows you to select the volume at which the DC-1 will power on. You can choose from a range of -80 to +12dB, or elect to have the system power on at the last level used (**LAST LVL**).

Power On Volume

This control in the Output Levels menu allows you to select the initial volume level for Zone 2. You can choose from a range of -80 to +12dB, or elect to have Zone 2 power on at the last level used (**LAST LVL**).

Zone 2 Volume

Setting Listener Position

The Listener Position menu is used for setting the surround and center delays and calibrating the Panorama effect.

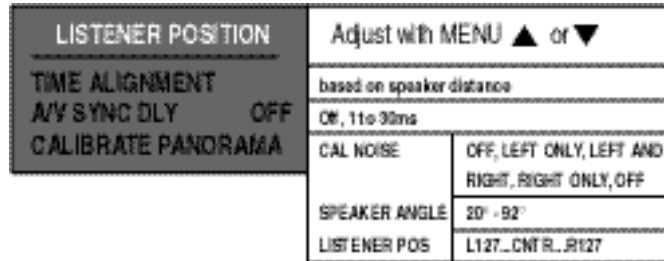

Surround Delay (Base and THX Versions)

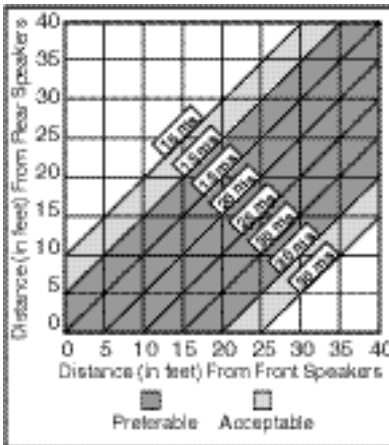

Surround Delay Settings

Note that the Time Alignment parameter replaced the Surround Delay parameter in Base and THX versions of the DC-1. The Surround Delay parameter is described below.

When presented with several similar sounds (as in the case of surround sound) we tend to localize on the first sound we hear. Because surround speakers are often closer to the listening area than the main speakers, occasional leakage of the front channel sound into the surround speakers can be audible and distracting. Delaying the sound from the surround speakers gives the sound from the front speakers a chance to reach the listener before the surrounds kick in. The SURROUND DELAY control in the Listener Position menu allows the user to set the surround delay between 15 and 30 milliseconds in one millisecond increments. The best setting will depend on the distance between the main listening area and the front speakers as well as the distance between the main listening area and the surround speakers. This global surround delay setting is used by surround effects that do not have their own surround delay setting.

Time Alignment (Dolby Digital version)

In the Dolby Digital version of the DC-1, the Time Alignment control electronically aligns all of the loudspeakers in a system. Although this adjustment is not a substitute for proper speaker placement, it will help to ensure accurate signal arrival times at the listening position.

To set up Time Alignment, you must physically measure the distance from the primary listening position to the front baffle of each individual speaker in your system. An easy and accurate way to accomplish this is to have a person sit in the primary listening position, holding the end of a measuring tape, while a second person extends the tape measure to the front baffle of each speaker in turn.

To enter these values, select TIME ALIGNMENT in the Listener Position menu and press SELECT. Use MENU ▲ and ▼ to highlight feet or meters and press SELECT. The display will change to show the Speaker Range menu. Use SELECT to highlight NEAREST SPKR and use MENU ▲ and ▼ to enter the actual distance. Press DONE.

Once you have entered the distance to the nearest speaker, the DC-1 will automatically calculate the maximum distance it can handle.

After the distance of the nearest speaker is entered, highlight TIME ALIGNMENT and press SELECT. A display will list all of the speakers, each with a default distance setting equal to your nearest speaker. Use SELECT and MENU ▲ and ▼ to highlight and enter actual distances for each speaker. The DC-1 rounds off distance settings into discrete steps – choose the closest step to the actual distance in these cases. If a speaker distance is further than the DC-1 can accommodate, set it to the maximum allowable distance. (This will vary, depending on your initial entry.)

Note that the Time Alignment parameter replaced the Center Delay parameter in Base and THX versions of the DC-1, which allowed electronic alignment of the center and left and right speakers.

The Center Delay parameter compensates for unequal distances between the center speaker and the listening position and the distance from the listening position to the left and right speakers. The delay (relative to the main left and right channels) can be adjusted between -5.0ms and +9.5 ms in 0.5 ms increments. To get the correct setting by ear, listen for a strong improvement in the imaging and stability of the soundstage.

Alternatively, you can measure the path length difference, and calculate the correct setting. To do this, measure the distance (in feet) from the tweeter(s) of your main speakers to your primary listening position. Average these two numbers. Measure the path length from the center speaker to your listening position, and subtract this distance from the average path length of the main speakers. Set CENTER DELAY to the same number of milliseconds as the number of feet of path length difference. For example, if the path length of your main speakers is 14', and the path length of your center speaker is 12', set the delay to +2ms. If the path length of the center speaker is 15.5', set the delay to -1.5ms. This adjustment globally affects all modes which use a center channel.

**Center Delay
(Base and THX versions)**

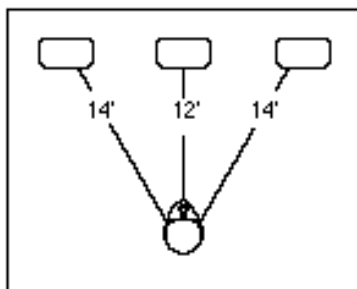
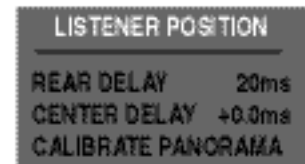

Set CENTER DELAY to 2ms.

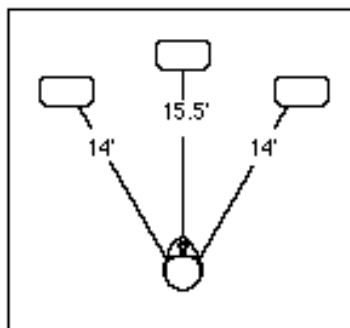

Set CENTER DELAY to -1.5ms.

A/V Sync Delay

A/V Sync Delay compensates for the delay that occurs when a video enhancing processor, such as a line doubler, is being utilized with the DC-1. Most of these enhancers alter the original audio/video timing relationship by adding processing delay to the video signal as it is passed through. A/V Sync Delay applies a corresponding delay to the audio signal to restore the original audio/video timing relationship. It can also be used to compensate for poorly mastered source material.

If your video material appears to be out of sync, add A/V Sync Delay in the LISTENER POSITION menu. With a video source running, adjust the delay along its 1-30ms range with MENU ▲ and ▼.

Calibrate Panorama

Panorama works by canceling the sound going from each speaker to the opposite ear. Its effectiveness is highly dependent on the geometry of your front loudspeakers, the room and your listening position. The correct timing of the canceling signal varies with the relative angle between your main speakers.

Find a mono source, such as an announcer on FM radio or a mono film, and listen for a tightly focused center image of speech or singing. If the image is off-center, adjust the DC-1's input balance controls. (The more centered the monaural image, the better Panorama will work.)

Select CALIBRATE PANORAMA from the Listener Position menu to display a sub-menu that allows you to turn on a calibration noise source, configure the speaker angle, and adjust the listener position.

CAL NOISE is a special digitally generated signal to aid in calibrating the Speaker Angle and Listener Position parameters. Note that in all cases, sound will actually be produced by both front loudspeakers. The adjustments affect the *perceived* directionality of the sound.

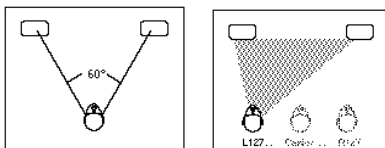

SPEAKER ANGLE is the angle between the main speakers as seen from the listening position — here it is about 60°. **LIS-TENER POS** allows you to adjust for an offset listening position.

The **SPEAKER ANGLE**, displayed in degrees, adjusts for wide or narrow speaker spacing (relative to the listening position). For the two canceling signals to arrive at both ears at the same time you must be centered precisely between the speakers. It will be easiest to calibrate this parameter if you start equidistant from the two front speakers, even if this is not your normal listening position. Once you have heard the effect and set the speaker angle, the Listener Position parameter will allow you to “move” the effect to your customary listening position.

To set the Speaker Angle, center yourself symmetrically between the two front speakers. Turn CAL NOISE on and select LEFT ONLY. The test signal should sound as though it is coming from off to your left side, well beyond the left speaker, with near-total silence in your right ear. Still facing forward, move your head from side to side until the effect is strongest. When you have found this *sweet spot* you will notice an almost physical sensation of silence in your right ear.

Now, select RIGHT ONLY. Again, shift your head from side to side to find the sweet spot, this time looking for the point where the sound is strongest in your *right* ear. Select LEFT AND RIGHT to determine if the sweet spots from the left and right tests coincide. If they do not coincide, return to the SPEAKER ANGLE display. If the first sweet spot is to the *left* of the second, press MENU ▲; if it is to the *right*, press MENU ▼.

If your normal listening position is not centered between your two front speakers, once you have corrected the speaker angle setting, you can "move" the sweet spot to that position. To do this, select LISTENER POS and use MENU ▲ and ▼ to move the effect. As you adjust the position, the display will indicate motion to the left of center (L001,L002,L003...L127), CENTER, or to the right of center (R001,R002,R003...R127). The numbers represent approximately 1/3", but are provided primarily as a general reference.

Panorama is now calibrated. Press DONE repeatedly to step back to the main setup menu.

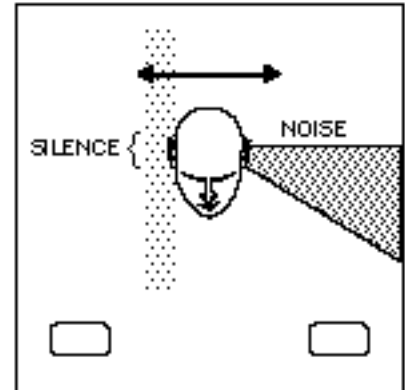

Move your head from side to side to find the position where the noise is full left, and the right ear hears near total silence.

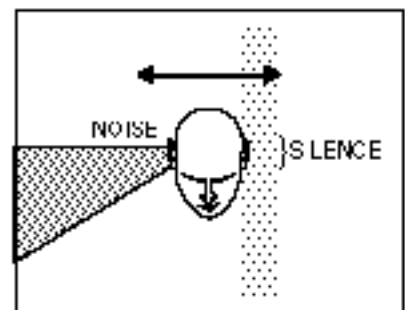

When calibrating right, if your left ear is in the silent band, the speaker angle is correct.

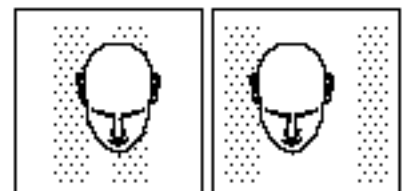

If the two silent bands are too close, lower the Speaker Angle; if they are too far apart, raise the Speaker Angle.

Customization

After you have calibrated and customized the DC-1, there are two additional steps recommended to safeguard the settings. First, document your adjustments using the table found at the end of this manual. Second, consider locking the settings so that they cannot be inadvertently changed. The last item in the Setup menu allows you to lock the DC-1 settings, as well as to change the name displayed during power up.

Locking Settings



Locking the settings allows full operation of the unit but prohibits the ability to change effect parameters or setup values. Specifically, with the settings locked, the unit will allow any Parameter or Setup menu to be displayed, but attempting to select any item for adjustment will display the message: **SETTINGS ARE LOCKED**.

In order to prevent accidental changes, select the **SETTINGS** parameter and use **MENU ▲** to select **LOCKED**. A higher level of security can be achieved by simultaneously pressing the **ACCY** and **DONE** keys on the remote after selecting **LOCKED**. To release lock, select **SETTINGS** and hold down **ACCY** and **DONE**. **MENU ▲** and **▼** will once again select **LOCKED** or **UNLOCKED**.

Assign Custom Name

When the DC-1 is first turned on, it displays a copyright notice with the current software version. You can choose to have it display **CUSTOMIZED FOR DEMONSTRATION** with the word **DEMONSTRATION** scrolled in from right to left, or you can replace the word **DEMONSTRATION** with a custom name of as many as 20 characters. To assign a new name, use **MENU ▲** and **▼** to highlight **CUSTOM NAME**. Press **SELECT** and press **MENU ▲** to turn this function **ON**, then press **DONE**.

You will return to the Lock Settings menu with **ASSIGN CUSTOM NAME** highlighted. Pressing **SELECT** will display the current name with a cursor indicating which character position can be modified. Use **MENU ▲** and **▼** to select a new character. Use **SELECT** to move the cursor to a new position. Press **DONE** to save the new name.

Audio Bit Setting (Dolby Digital Version)

The DC-1 is designed to automatically detect and decode Dolby Digital and PCM stereo digital bitstreams. This auto-detection feature can be manually defeated in order, for example, to play Dolby Digital bitstreams from a DAT player by changing the Audio Bit setting from **AUTOMATIC** to **AUDIO** or **NON-AUDIO**. To play Dolby Digital data from a DAT, set this control to **NON-AUDIO**.

The THX and Dolby Digital versions of the DC-1 provide Equalization controls as a selection in the Main Menu.

Press SELECT to open the Equalization menu which contains Bass and Treble level controls and a Loudness parameter. The Dolby Digital version also contains a Tilt parameter.

EQUALIZATION MENU		Adjust with MENU ▲ or ▼
BASS LEVEL	±0.0dB	-6.0 to +6.0dB
TREBLE LEVEL	±0.0dB	-6.0 to +6.0dB
TILT	±0.0dB	-3.0dB to +3.0dB
LOUDNESS	ON	ON, OFF

Equalization (THX and Dolby Digital versions)



Bass and Treble level controls are provided to compensate for inconsistencies in source material, rather than variations in room conditions. The BASS LEVEL control allows a boost or cut of as much as 6dB below 250Hz. The TREBLE LEVEL control allows a boost or cut of 6dB above 1.5kHz.

Bass and Treble Level

To select either control for adjustment, use MENU ▲ or ▼ to select the control, press SELECT, and use MENU ▲ or ▼ to adjust the setting.

These controls do not affect the sound of rear or side speakers.

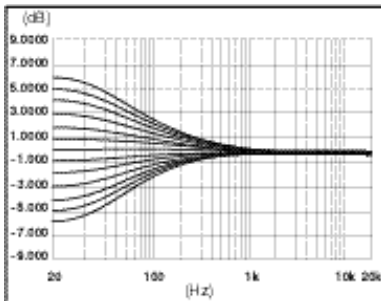

Bass Tone Control Frequency Response

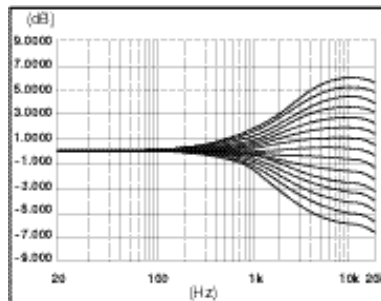

Treble Tone Control Frequency Response

Tilt (Dolby Digital version)

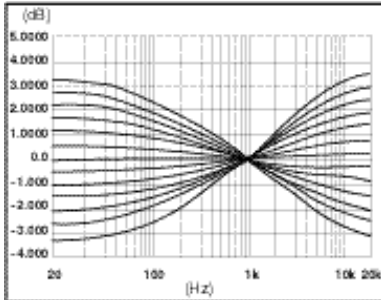

Tilt Control Frequency Response

The Tilt parameter can be thought of as a straight line that pivots on a fulcrum at 1kHz to correct the overall tonal balance of source material. The range is -3.0dB to +3.0dB, referenced to the Treble level. This control, adjustable in 0.2dB increments, is useful on many older recordings, or when the desired tonal balance cannot be achieved using the Bass, Treble and Loudness controls. The Tilt control does not alter the tonal balance of the rear or side speakers.

Loudness

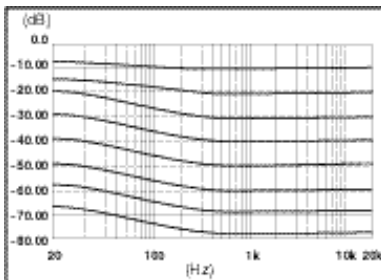

Loudness vs DC-1 Volume control
(front left)

A Loudness Contour parameter which boosts bass information, provides more balanced reproduction at low volume listening conditions. Once you have calibrated DC-1 output levels, you can assume a specific acoustic level for a given volume setting and set the LOUDNESS parameter ON to provide the ideal amount of boost for any given volume setting. This parameter does not affect the sound in rear or side speakers.

When EFFECT ADJUST is selected from the Main menu, the on-screen display shows a list of parameters specific to the current effect, as well as the current value of each parameter. (The front panel display shows one parameter at a time). Press the MENU ▲ and ▼ buttons to move through the displayed list. Press SELECT to activate a two-line display which allows you to use the ▲ and ▼ buttons to alter the selected parameter's value. Press DONE to confirm the change and move on to the next menu item. Each DC-1 Effect and its parameter menu is described in the following section.

Although the list of available parameters will vary with different effects, the last item in each menu is always CUSTOM. Selecting CUSTOM calls up a sub-menu which allows you to name your custom effects, to compare your version with the original preset, or to restore the preset versions of the Effect name and parameter values.

When first shipped, the DC-1 has a set of default values assigned to each Effect. These values have been determined to be generally suitable for initial listening. As every installation has its own unique characteristics, and listeners have distinctly different preferences, you will want to tailor the Effects to suit your own requirements. To allow easy customization, any parameter changes you make take effect instantly, and automatically become a part of the Effect. You can even change the name that appears on-screen. Once you have made the changes you want, the Effect will remain as you have set it unless you alter it again, or deliberately restore the factory preset parameter values.

Selecting CUSTOM from any Effect Adjust menu will give you access to the controls listed to the side and described below. Use MENU ▲ and ▼ to highlight any menu item, then press SELECT to open the submenu.

LISTEN CUSTOM/PRESET lets you compare your edited version of an Effect with the original version as set at the factory. When this control is selected, MENU ▲ and ▼ allow you to alternate between the "preset" and your modified version ("custom"). The display will confirm whether you are LISTENING TO CUSTOM or PRESET.

Note that this function is available, even if you have not made any changes to an Effect. Until you make parameter changes to create a custom version of a preset, the LISTEN TO CUSTOM option will contain an exact duplicate of the preset Effect.

DC-1 Effects



Customizing Effects

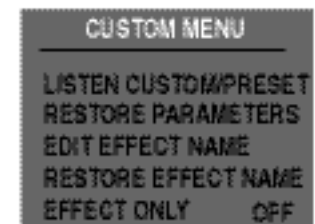

Comparing a modified Effect to the factory preset version

**Restoring the original
parameter values
of an Effect**

The RESTORE PARAMETERS function allows you restore the currently selected Effect to its factory preset state.

When you select this function, you will be prompted to reconsider erasing your changes. — If you *don't* want to erase your versions, press DONE to exit the menu. Pressing SELECT in response to the displayed query will restore all of the factory preset values to the Effect.

Naming your custom Effect

EDIT EFFECT NAME allows you to assign a new name, of as many as 13 characters, to your Effect. With EDIT EFFECT NAME highlighted, press SELECT to display the current name with a cursor indicating which character position can be modified. SELECT moves the cursor to a new position. MENU ▲ and ▼ scroll through the available character set. Press DONE to save the new name.

**Restoring the original
Effect name**

RESTORE EFFECT NAME allows you to restore the original factory name of an Effect, without changing any of your modified parameter settings. When you select this function, the message PRESS SELECT TO RESTORE EFFECT NAME allows you to reconsider erasing your custom name. — If you *don't* want to erase your version, press DONE to exit the menu. Pressing SELECT in response to the displayed query will restore the factory preset name.

**Listening to only
the DC-1 Effect**

Selecting EFFECT ONLY allows you to listen to only the effects added by the DC-1 to the currently loaded program. With this function selected, use MENU ▲ and ▼ to turn this function on or off.

Music Surround, available in the THX and Dolby Digital versions of the DC-1, is a surround effect developed specifically for music listening. It makes full use of additional loudspeakers placed at the center, sides and rear of the room. This effect passes unprocessed left and right information directly to the front left and right speakers.

Music Surround (THX and Dolby Digital versions)

Parameter	Initial Value	Range
CENTER LEVEL	15	0-30
SURROUND LEVEL	+0dB	-5 to +5dB
SIDE ROLLOFF	4.0kHz	453Hz20.0kHz
REAR DELAY OFFSET	5ms	0-20ms
REAR ROLLOFF	4.0kHz	453Hz20.0kHz
SUBWOOFER LVL	+0dB	-5 to +5dB
EFFECT LEVEL	+00dB	-30 to +05dB
CUSTOM		

Music Surround Parameters

CENTER LEVEL attenuates the level of the center channel and can turn it off completely.

SURROUND LEVEL controls the volume level of the side and rear speakers. Although we have selected a default value, the correct setting will vary with each recording, the room, and your personal taste.

SIDE ROLLOFF provides a high frequency cutoff for the side speakers. The optimal setting for this control will vary widely with the source material.

REAR DELAY OFFSET is an additional delay added to the rear channels. This delay increases the apparent size of the listening space by increasing the rear delay time. Feel free to experiment to find the setting that works best.

REAR ROLLOFF sets the cutoff frequency of a low pass filter in the rear-channel. Frequencies above this setting are attenuated. This control should be set high enough to give presence and airiness to the rear sound without placing distracting instrumental overtones or other sounds behind you. In systems configured without rear speakers, the settings affect the *side* outputs.

SUBWOOFER LVL boosts or cuts the subwoofer output level. Although the normal subwoofer level is set during the calibration procedure, with some recordings it may be desirable to increase or decrease this deep bass level.

EFFECT LEVEL adjusts the loudness of the side and rear speakers. When there are no side speakers, it adjusts the amount of ambient signal mixed into the main loudspeakers.

Pro Logic This Effect provides Dolby Pro Logic Surround decoding designed for any Dolby Surround encoded movies, music, or television programs. The Pro Logic effect is an industry standard. Lexicon's proprietary auto azimuth correction makes it an improvement over other versions. (Even more dramatic improvement has been implemented in more recent effects, such as Logic 7 or TV Matrix.)

Pro Logic Parameters

Parameter	Initial Value	Range
AUTO AZIMUTH	ON	ON/OFF
DIALOG ENHANCE	0.0dB	0.0dB, +3.0dB, +6.0dB
SUBWOOFER LVL	+0dB	-5 to +5dB
EFFECT LEVEL	+00dB	-30 to +05dB
CUSTOM		

AUTO AZIMUTH is short for auto azimuth error correction/automatic input balance. Auto Azimuth should be set to ON for films, and OFF for music. When ON, special patented algorithms continually monitor the input signal and adjust both the relative level and time offset of the two channels to keep the dialog properly centered and special effects properly localized. This automatic feature is the reason the unit does not need an input balance control for Dolby Surround decoding.

DIALOG ENHANCE boosts dialog in the center channel. By targeting specific frequencies, it boosts dialog without raising the entire center channel level (which would alter the output balance achieved during calibration).

SUBWOOFER LVL boosts or cuts the subwoofer output level. Although the normal subwoofer level is set during the calibration procedure, with some recordings it may be desirable to increase or decrease this deep bass level.

EFFECT LEVEL adjusts the loudness of all speakers except the center channel. This can be extremely useful in compensating for soundtracks in which the dialog level is too low (decrease EFFECT LEVEL) or when you want to make the surround presentation more spectacular (increase EFFECT LEVEL).

This Effect, available only in DC-1's equipped with THX or Dolby Digital processing, provides Home THX Cinema surround decoding for any Dolby surround encoded movies, music or television programs. The effect is similar to Pro Logic, but includes the features of re-equalization, timbre matching and decorrelation. The surround channels are monaural, but can be decorrelated. This effect can be reset to use the Logic 7 stereo surrounds with the Stereophonic setting of Surround Mode, although full separation between the sides and the rear speakers is not available.

THX Cinema (THX and Dolby Digital versions)

Parameter	Initial Value	Range
AUTO AZIMUTH	ON	ON/OFF
SURROUND MODE	DECORR	STEREO, DECORR
RE-EQUALIZER	ON	ON/OFF
SUBWOOFER LVL	+0dB	-5 to +5dB
CUSTOM		

THX Cinema Parameters

AUTO AZIMUTH is short for auto azimuth error correction/automatic input balance. Auto Azimuth should be set to ON for films, and OFF for music. When ON, special patented algorithms continually monitor the input signal and adjust both the relative level and time offset of the two channels to keep the dialog properly centered and special effects properly localized. This automatic feature is the reason the unit does not need an input balance control for Dolby Surround decoding.

SURROUND MODE selects the type of surround decoding used by the DC-1. STEREOPHONIC provides extraction of five channels of surround information from a standard 4-2-4 matrix-encoded soundtrack (Dolby Surround, Ultra*Stereo, etc.) The drama of this effect is dependent on the source material and is most noticeable with strong stereo music soundtracks. The DECORRELATED setting electronically scrambles the monaural surround channel to provide added spaciousness and envelopment.

RE-EQUALIZER equalizes the left, center, and right channel outputs to match the overall frequency balance of the original recording. Without this re-equalization, many films and some television programs will sound too bright.

SUBWOOFER LVL boosts or cuts the subwoofer output level. Although the normal subwoofer level is set during the calibration procedure, with some recordings it may be desirable to increase or decrease this deep bass level.

Logic 7 (THX and Dolby Digital versions)

Available only in the THX and Dolby Digital versions of the DC-1, this film sound mode reproduces musical material with maximum separation at all times, whether or not directional material is being steered. In addition, Logic 7 uses intelligent steering to extract wide bandwidth stereo surround channels. If both side and rear speaker pairs are available, signals may be steered between the left side and left rear, or between the right side and right rear. It is also possible for a signal to be steered fully to the rear speakers, with the side surround speakers 6dB lower than the rears to provide subjective rear imaging.

Logic 7 contains the re-equalizer feature of the THX Cinema effect, as well as Lexicon's proprietary dialog enhancement feature. The combination of stereo surround information during music and decorrelated effects, with discrete steering to the sides and rears, gives Logic 7 unrivaled performance on surround encoded films.

Logic 7 Parameters

Parameter	Initial Value	Range
AUTO AZIMUTH	ON	ON/OFF
DIALOG ENHANCE	0.0dB	0.0dB, +3.0dB, +6.0dB
REAR ROLLOFF	8.2kHz	453Hz-20.0kHz
REAR DELAY OFFSET	5ms	0-20ms
RE-EQUALIZER	ON	ON/OFF
SIDE ASSIGN	SIDE	Front/Side, Front/Rear*
SURROUND LEVEL	+0dB	-5 to +5dB
SUBWOOFER LVL	+0dB	-5 to +5dB
EFFECT LEVEL	+0dB	-30 to +05dB
CUSTOM		

* Dependent on speaker configuration

AUTO AZIMUTH is short for auto azimuth error correction/automatic input balance. Auto Azimuth should be set to ON for films, and OFF for music. When ON, special patented algorithms continually monitor the input signal and adjust both the relative level and time offset of the two channels to keep the dialog properly centered and special effects properly localized. This automatic feature is the reason the unit does not need an input balance control for Dolby Surround decoding.

DIALOG ENHANCE boosts dialog in the center channel. By targeting specific frequencies, it boosts only dialog, without raising the entire center channel level (which would alter the output balance achieved during calibration).

REAR ROLLOFF sets the cutoff frequency of a low pass filter in the rear-channel. Frequencies above this setting are attenuated. This control should be set high enough to give presence and airiness to the rear sound without placing distracting instrumental overtones or other sounds behind you. In systems configured without rear speakers, the settings affect the *side* outputs.

REAR DELAY OFFSET is an additional delay added to the rear channels. This delay increases the apparent size of the listening space by increasing the rear delay time. Feel free to experiment to find the setting that works best.

RE-EQUALIZER equalizes the left, center, and right channel outputs to match the overall frequency balance of the original recording. Without this re-equalization, many films and some television programs will sound too bright.

SIDE ASSIGN determines whether the information fed to the side speakers is from the front, side or rear outputs. Availability of selections varies according to your speaker configuration. Choosing **FRONT** will give a much larger front sound stage. Choosing **SIDE** or **REAR** will provide a more enveloping surround field.

SURROUND LEVEL controls the volume level of the side and rear speakers. Although we have selected a default value, the correct setting will vary with each recording, the room, and your personal taste. Raising the level will provide a more enveloping surround field.

SUBWOOFER LVL boosts or cuts the subwoofer output level. Although the normal subwoofer level is set during the calibration procedure, with some recordings it may be desirable to increase or decrease this deep bass level.

EFFECT LEVEL adjusts the loudness of all channels except for the center.

THX versions of the DC-1 contained a version of the LOGIC 7 effect with the menu items described below:

DOLBY B NR is used in Pro Logic and THX effects for the surround channels according to Dolby specifications. Because Dolby Surround encoded program material is generally listened to with the unit set for Pro Logic or THX, this parameter is normally off.

FRONT STEERING adjusts the amount of steering in the front channels. At **FULL**, the steering is identical to Dolby Pro Logic. At **1/2**, steering is reduced to accommodate the wide range of television programming. Selecting **OFF** steers the center signal to both the left and right channels. This parameter is automatically set to **OFF** for systems configured without a center speaker.

Note that these systems did not contain **DIALOG ENHANCE** and **REAR DELAY OFFSET**, which were made available as LOGIC 7 parameters as of the release of the Dolby Digital version of the DC-1.

TV Matrix

The TV Matrix effect provides surround effects for television viewing of monaural, stereo, and stereo synthesized programs.

TV Matrix Parameters

Parameter	Initial Value	Range
AUTO AZIMUTH	ON	ON/OFF
FRONT STEERING	FULL	1/4, 1/2, Full, Off
REAR ROLLOFF	8.2kHz	453Hz-20.0kHz
DOLBY B NR	OFF	ON/OFF
RE-EQUALIZER	OFF	ON/OFF
SIDE ASSIGN	SIDE	Front/Side, Front/Rear*
SURROUND LEVEL	+0dB	-5 to +5dB
SUBWOOFER LVL	0dB	-5 to +5dB
EFFECT LEVEL	+00dB	-30 to +05dB
CUSTOM		

* Dependent on speaker configuration

AUTO AZIMUTH is short for auto azimuth error correction/automatic input balance. Auto Azimuth should be set to ON for films, and OFF for music. When ON, special patented algorithms continually monitor the input signal and adjust both the relative level and time offset of the two channels to keep the dialog properly centered and special effects properly localized. This automatic feature is the reason the unit does not need an input balance control for Dolby Surround decoding.

FRONT STEERING The essence of the TV MATRIX Effect is that dialog, music, and surround effects are dynamically directed to the output channels, a process called steering. The FRONT STEERING control allows you to adjust the amount of steering in the front channels. When this control is set to FULL, the steering is identical to Dolby Pro Logic. At 1/2, steering is reduced to accommodate the wide range of television programming. Selecting OFF will steer the center signal to both the left and right channels. This parameter is automatically set to OFF for systems configured without a center speaker.

REAR ROLLOFF sets the cutoff frequency of a low pass filter in the rear-channel. Frequencies above this setting are attenuated. This control should be set high enough to give presence and airiness to the rear sound without placing distracting instrumental overtones or other sounds behind you. In systems configured without rear speakers, the settings affect the *side* outputs.

DOLBY B NR is used in Pro Logic and THX effects for the surround channels according to Dolby specifications. Because Dolby Surround encoded program material is generally listened to with the unit set for Pro Logic or THX, this parameter is normally off.

RE-EQUALIZER equalizes the left, center, and right channel outputs to match the overall frequency balance of the original recording. Without this re-equalization, many films and some television programs will sound too bright.

SIDE ASSIGN determines whether the information fed to the side speakers is from the front, side or rear outputs. Availability of selections varies according to your speaker configuration. Choosing **FRONT** will give a much larger front sound stage. Choosing **SIDE** or **REAR** will provide a more enveloping surround field.

SURROUND LEVEL controls the volume level of the side and rear speakers. Although we have selected a default value, the correct setting will vary with each recording, the room, and your personal taste. Raising the level will provide a more enveloping surround field.

SUBWOOFER LVL boosts or cuts the subwoofer output level. Although the normal subwoofer level is set during the calibration procedure, with some recordings it may be desirable to increase or decrease this deep bass level.

EFFECT LEVEL adjusts the loudness of all channels except for the center.

Mono Logic

Mono Logic takes a monaural soundtrack and sends music and sound effects to the sides and rear through a room simulator mode while keeping the dialog in the center.

Mono Logic Parameters

Parameter	Initial Value	Range
ROLLOFF	3.3kHz	453Hz to 20.0kHz
ACADEMY FILTER	ON	ON/OFF
MAIN LEVEL	8	0-16
SUBWOOFER LVL	+0dB	-5 to +5dB
EFFECT LEVEL	-04dB	-30 to +05dB
CUSTOM		

ROLLOFF regulates the treble cut in the side and rear channels. The optimal setting for this parameter will vary widely with the age, quality, and condition of the source material.

ACADEMY FILTER is provided to recreate the proper tonal balance of older monaural films that were recorded with much narrower and duller frequency response than current films.

MAIN LEVEL controls the level of the mono signal that is reproduced by the main speakers. When a center speaker is part of the configuration many films may sound better when this control is set between 6-12. This spreads the film sound out around the screen and can be more pleasant than restricting the dialog and much of the other film sound to the center speaker.

SUBWOOFER LVL boosts or cuts the subwoofer output level. Although the normal subwoofer level is set during the calibration procedure, with some recordings it may be desirable to increase or decrease this deep bass level.

EFFECT LEVEL adjusts the loudness of the side and rear speakers. When there are no side speakers, it adjusts the amount of ambient signal mixed into the main loudspeakers.

Panorama extracts the natural ambience from recorded music and moves it outward from the speakers, producing greater width and depth of image and a feeling of enhanced spaciousness. This mode adds no additional sound but expands the existing stereo image. Panorama also works with Dolby Stereo movies, bringing the surround track outward into the room.

Panorama

The location of the front speakers and the listening position are crucial to Panorama's effectiveness and for best results your system and the DC-1 together should be set up and calibrated according to the procedure in Chapter 2. The strength of the Panorama effect drops off as you move away from the prime listening position, especially to the sides. Video systems with the main loudspeakers spaced closely on either side of a TV screen will produce a usable effect over a somewhat wider area than set-ups with a large included angle between the speakers.

Parameter	Initial Value	Range
INPUT BALANCE	(Centered)	Full Left-Full Right
LOW FREQ WIDTH	0	-25 to +25
REAR LEVEL	25	0-32
REAR ROLLOFF	4.9kHz	453Hz-20.0kHz
REAR DELAY	10ms	0-32ms
CENTER LEVEL	4	0-15
BASS CONTENT	MONO	STEREO, MONO, BINAURAL
SUBWOOFER LVL	+0dB	-05 to +05dB
EFFECT LEVEL	62	0-62
CUSTOM		

Panorama Parameters

INPUT BALANCE allows you to compensate for the occasional source with audible channel imbalance. When selected, screen graphics indicate the relative left/right position.

LOW FREQ WIDTH allows you to apply low-frequency spatial correction to the signal. Positive values of LOW FREQ Width indicate that the *difference* signal (L-R) has additional energy below 500Hz, while the *sum* (L+R) has correspondingly less. Negative settings of LOW FREQ WIDTH can compensate for recordings with too much of this property. This control can add needed spaciousness and warmth to classical recordings made with coincident or near-coincident microphones.

REAR LEVEL adjusts the loudness of the signals sent to the rear channels. This control should be set so that the rear is audible without calling attention to itself. Numerical values and screen graphics are displayed during adjustment. In systems configured without rear speakers, the settings affect the level of the *side* outputs.

REAR ROLLOFF sets the frequency above which the rear-channel sound is attenuated. The appropriate setting will vary with the program material. It should be set high enough to give presence and airiness to the rear sound without placing distracting instrumental overtones or other sounds behind you. In systems configured without rear speakers, the settings affect the *side* outputs.

REAR DELAY adjusts the amount of time between the appearance of a signal in the front channels and its emergence from the rear. Generally, the correct delay is about 16 milliseconds, but the setting depends on speaker set-up and source material. In general, the delay should be low enough so that the rear sound does not become identifiable as a distinct source. In systems configured without rear speakers, the settings affect the *side* outputs.

CENTER LEVEL adjusts the output level from the center speaker.

BASS CONTENT allows you to modify the bass content for Mono, Stereo or Binaural recordings. The **BINAURAL** setting turns the rear level parameter off and activates special low-frequency compensation. This feature is offered specifically for true binaural recordings made with a dummy head.

SUBWOOFER LVL boosts or cuts the subwoofer output level. Although the normal subwoofer level is set during the calibration procedure, with some recordings it may be desirable to increase or decrease this deep bass level.

EFFECT LEVEL adjusts the loudness of the side and rear speakers. When there are no side speakers, it adjusts the amount of ambient signal mixed into the main loudspeakers.

The Nightclub Effect generates the appropriate early reflections for stereo simulation of many different intimate spaces, and sends the reflections to the front, side and rear speakers.

Nightclub

Parameter	Initial Value	Range
HALL SIZE	4 Meters	4-17 Meters
LIVENESS	4	0-6
ROLLOFF	9.7kHz	453Hz-20.0kHz
SPEECH DETECT	OFF	ON/OFF
CENTER LEVEL	9	0-15
SUBWOOFER LVL	+0dB	-5 to +5dB
EFFECT LEVEL	+02dB	-30 to +05dB
CUSTOM		

Nightclub Parameters

HALL SIZE allows you to select room sizes of lengths ranging from 4-17 meters.

LIVENESS adjusts the amount of recirculation within the effect. Higher values mimic more reflective surfaces in the simulated space and increase the amount of time it takes the sound to decay. At very high values, the decay is audibly less smooth than in the Church and Cathedral Effects, which are more effective at simulating very live spaces.

ROLLOFF mimics the absorption of the air in the hall and, typically, should begin with a low frequency to simulate large spaces.

SPEECH DETECT activates a circuit that distinguishes monaural speech from other inputs. Essentially, this control turns down the effect to make speech clearer. Whenever stereo signals are present, the right and left input channels are used independently as inputs to the ambience synthesis. If there is a strong monaural speaking voice present at the same time, this component of the input to the Nightclub effect is reduced while the stereo component is increased.

If the input signal is pure monaural speech the reverb is almost entirely attenuated. **SPEECH DETECT** is a real benefit to some popular music (where spoken voice, such as rap, occurs along with the music), stereo television and early stereo movies. Any stereo material which was not carefully mixed for Surround is a good candidate for playing through the Nightclub Effect with speech detect on.

CENTER LEVEL adjusts the output level from the center speaker.

SUBWOOFER LVL boosts or cuts the subwoofer output level. Although the normal subwoofer level is set during the calibration procedure, with some recordings it may be desirable to increase or decrease this deep bass level.

EFFECT LEVEL adjusts the loudness of the side and rear speakers. When there are no side speakers, it adjusts the amount of ambient signal mixed into the main loudspeakers.

Concert Hall

The Concert Hall Effect generates the appropriate early reflections for stereo simulation of many different halls, and sends the reflections to all channels in addition to the direct signal in the main speaker. This Effect is not appropriate for highly percussive music.

Concert Hall Parameters

Parameter	Initial Value	Range
HALL SIZE	30 Meters	20-30 Meters
LIVENESS	4	0-6
ROLLOFF	3.3kHz	453Hz-20.0kHz
SPEECH DETECT	ON	ON/OFF
CENTER LEVEL	8	0-15
SUBWOOFER LVL	+0dB	-5 to +5dB
EFFECT LEVEL	-01dB	-30 to +05dB
CUSTOM		

HALL SIZE allows you to select room sizes of lengths ranging from 20-30 meters (in increments of 4 meters).

LIVENESS adjusts the amount of recirculation within the effect. Higher values mimic more reflective surfaces in the simulated space and increase the amount of time it takes the sound to decay. At very high values, the decay is audibly less smooth than in the Church and Cathedral Effects, which are more effective at simulating very live spaces.

ROLLOFF mimics the absorption of the air in the hall and, typically, should begin with a low frequency to simulate large spaces.

SPEECH DETECT activates a circuit that distinguishes monaural speech from other inputs. Essentially, this control turns down the effect to make speech clearer. Whenever stereo signals are present, the right and left input channels are used independently as inputs to the ambience synthesis. If there is a strong monaural speaking voice present at the same time, this component of the input to the Concert Hall effect is reduced while the stereo component is increased.

If the input signal is pure monaural speech the reverb is almost entirely attenuated. SPEECH DETECT is a real benefit to some popular music (where spoken voice, such as rap, occurs along with the music), stereo television and early stereo movies. Any stereo material which was not carefully mixed for surround is a good candidate for playing through the Concert Hall effect with Speech Detect on.

CENTER LEVEL adjusts the output level from the center speaker.

SUBWOOFER LVL boosts or cuts the subwoofer output level. Although the normal subwoofer level is set during the calibration procedure, with some recordings it may be desirable to increase or decrease this deep bass level.

EFFECT LEVEL adjusts the loudness of the side and rear speakers. When there are no side speakers, it adjusts the amount of ambient signal mixed into the main loudspeakers.

The Church Effect uses a reverberation algorithm, which differs from ambience in that it does not simulate the reflections of specific halls, but emphasizes rich, smooth reverberant decay in small and medium spaces. It works well for simulating a space with a long reverberation time relative to its size, such as a reverberant chamber, or a church.

Church

Parameter	Initial Value	Range
MID RT	1.89 sec	.89-13.42 sec
BASS RT	2.36 sec	0.7, 1.0, 1.25xMID RT
HALL SIZE	30 Meters	4-30 Meters
PRE-DELAY	24ms	0-88ms
ROLLOFF	2.6kHz	453Hz-20.0kHz
SPEECH DETECT	ON	ON/OFF
CENTER LEVEL	7	0-15
SUBWOOFER LVL	+0dB	-5 to +5dB
EFFECT LEVEL	-01dB	-30 to +05dB
CUSTOM		

Church Parameters

MID RT (midrange reverberation time) is the time required for midrange sounds to decay 60dB in level.

BASS RT (low frequency reverberation time) depends on MID RT and is expressed as a multiplier. BASS RT should be set to 1.0 x MID RT for a more natural effect in smaller spaces.

HALL SIZE allows you to select hall sizes of lengths ranging from 4-30 meters (in increments of 2 meters).

PRE-DELAY increases the delay between the direct sound and the onset of reverberation. Because some pre-delay is inherent in the program material, a value of 0 is usually a good starting point. Increasing the pre-delay value will make the hall sound larger.

ROLLOFF mimics the absorption of the air in the hall and, typically, should begin with a low frequency when simulating larger spaces.

SPEECH DETECT activates a circuit that distinguishes monaural speech from other inputs. Essentially, this control turns down the effect to make speech clearer. Whenever stereo signals are present, the right and left input channels are used independently as inputs to the ambience synthesis. If there is a strong monaural speaking voice present at the same time, this component of the input to the Church effect is reduced while the stereo component is increased.

If the input signal is pure monaural speech the reverb is almost entirely attenuated. SPEECH DETECT is a real benefit to some popular music (where spoken voice, such as rap, occurs along with the music), stereo television and early stereo movies. Any stereo material which was not carefully mixed for surround is a good candidate for playing through the Church effect with Speech Detect on.

CENTER LEVEL adjusts the output level from the center speaker.

SUBWOOFER LVL boosts or cuts the subwoofer output level. Although the normal subwoofer level is set during the calibration procedure, with some recordings it may be desirable to increase or decrease this deep bass level.

EFFECT LEVEL adjusts the loudness of the Effect.

Cathedral

The Cathedral Effect uses a reverberation algorithm which emphasizes rich, smooth reverberant decay in large spaces. As its name indicates, it works well for simulating a space with a long reverberation time relative to its size, such as a cathedral.

Cathedral Parameters

Parameter	Initial Value	Range
MID RT	3.90 sec	1.14-17.04 sec
BASS RT	4.87 sec	0.7, 1.0, 1.25xMID RT
HALL SIZE	38 Meters	20-38 Meters
PRE-DELAY	40ms	0-88ms
ROLLOFF	2.6kHz	453Hz-20.0kHz
SPEECH DETECT	ON	ON/OFF
CENTER LEVEL	7	0-15
SUBWOOFER LVL	+0dB	-5 to +5dB
EFFECT LEVEL	-01dB	-30 to +05dB
CUSTOM		

MID RT (midrange reverberation time) is the time required for midrange sounds to decay 60dB in level.

BASS RT (low frequency reverberation time) depends on MID RT and is expressed as a multiplier. BASS RT should be set to 1.0 x MID RT for a more natural effect in smaller spaces.

HALL SIZE allows you to select hall sizes of lengths ranging from 20-38 meters (in increments of 2 meters).

PRE-DELAY increases the delay between the direct sound and the onset of reverberation. Because some pre-delay is inherent in the program material, a value of 0 is usually a good starting point. Increasing the pre-delay value will make the hall sound larger.

ROLLOFF mimics the absorption of the air in the hall and, typically, should begin with a low frequency when simulating larger spaces.

SPEECH DETECT activates a circuit that distinguishes monaural speech from other inputs. Essentially, this control turns down the effect to make speech clearer. Whenever stereo signals are present, the right and left input channels are used independently as inputs to the ambience synthesis.

If there is a strong monaural speaking voice present at the same time, this component of the input to the Cathedral effect is reduced while the stereo component is increased.

If the input signal is pure monaural speech the reverb is almost entirely attenuated. SPEECH DETECT is a real benefit to some popular music (where spoken voice, such as rap, occurs along with the music), stereo television and early stereo movies.

CENTER LEVEL adjusts the output level from the center speaker.

SUBWOOFER LVL boosts or cuts the subwoofer output level. Although the normal subwoofer level is set during the calibration procedure, with some recordings it may be desirable to increase or decrease this deep bass level.

EFFECT LEVEL adjusts the loudness of the side and rear speakers. When there are no side speakers, it adjusts the amount of ambient signal mixed into the main loudspeakers.

Music Logic is a surround effect developed specifically for music listening. It makes full use of additional loudspeakers placed at the center, sides and rear of the room and provides a slight degree of steering for the front channels. (Music Surround, available in the THX and Dolby Digital versions of the DC-1, passes unprocessed left and right information directly to the front left and right speakers.)

Music Logic

Parameter	Initial Value	Range
CENTER LEVEL	16	0-30
FRONT STEERING	FULL	1/4, 1/2, Full, Off
SURROUND LEVEL	+0dB	-5 to +5dB
SIDE ROLLOFF	4.0kHz	453Hz20.0kHz
REAR ROLLOFF	4.0kHz	453Hz20.0kHz
SUBWOOFER LVL	+0dB	-5 to +5dB
EFFECT LEVEL	+00dB	-30 to +05dB
CUSTOM		

Music Logic Parameters

CENTER LEVEL attenuates the level of the center channel and can turn it off completely.

FRONT STEERING (available only in Music Logic) allows you to adjust the amount of steering in the front channels. When this control is set to FULL, the effect is identical to Dolby Pro Logic. At the 1/2 and 1/4 settings, steering is reduced to accommodate the wide range of television programming. Selecting OFF steers the signal to both the left and right channels.

SURROUND LEVEL controls the volume level of the side and rear speakers. Although we have selected a default value, the correct setting will vary with each recording, the room, and your personal taste.

SIDE ROLLOFF provides a high frequency cutoff for the side speakers. The optimal setting for this control will vary widely with the source material.

REAR ROLLOFF sets the cutoff frequency of a low pass filter in the rear-channel. Frequencies above this setting are attenuated. This control should be set high enough to give presence and airiness to the rear sound without placing distracting instrumental overtones or other sounds behind you. In systems configured without rear speakers, the settings affect the *side* outputs.

SUBWOOFER LVL boosts or cuts the subwoofer output level. Although the normal subwoofer level is set during the calibration procedure, with some recordings it may be desirable to increase or decrease this deep bass level.

EFFECT LEVEL adjusts the loudness of the side and rear speakers. When there are no side speakers, it adjusts the amount of ambient signal mixed into the main loudspeakers.

The Party effect allows unprocessed stereo signals to be played over all speakers for background music or for maximum acoustical output of the system.

Party

Parameter	Initial Value	Range
HIGH PASS	40Hz	OFF, 40-735Hz
CENTER LEVEL	15	0-15
SUBWOOFER LVL	+0dB	-5 to +5dB
EFFECT LEVEL	+0dB	-30 to +05dB
CUSTOM		

Party Parameters

HIGH PASS sets the level of a filter which removes low frequencies from the center, side, and rear outputs. This is useful if the system is being used at high volumes where low frequencies might damage smaller speakers.

CENTER LEVEL attenuates the level of the center channel as much as 15 dB. A numerical value and horizontal bar are shown by the front panel and on-screen displays during adjustment.

SUBWOOFER LVL boosts or cuts the subwoofer output level. Although the normal subwoofer level is set during the calibration procedure, with some recordings it may be desirable to increase or decrease this deep bass level.

EFFECT LEVEL adjusts the loudness of the center, side and rear speakers.

The Two Channel effect allows you to use your system for two channel stereo playback.

Two Channel

Parameter	Initial Value	Range
SUBWOOFER LVL	+0dB	-5 to +5dB
CUSTOM		

Two Channel Parameters

SUBWOOFER LVL boosts or cuts the subwoofer output level. Although the normal subwoofer level is set during the calibration procedure, with some recordings it may be desirable to increase or decrease this deep bass level.

AC-3 Status Display (Dolby Digital version)

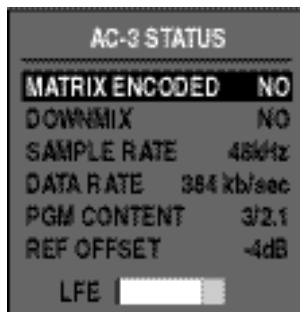

The following five effects are available only in the Dolby Digital version of the DC-1. Each of these effects provides an AC-3 Status Display in the parameter menu. This display contains the following information.

MATRIX ENCODED: YES indicates a Dolby Digital input is matrix encoded; **No** indicates it is not.

DOWNMIX: YES indicates material is being downmixed for speaker configuration, or because a two-channel effect is being utilized; **NO** indicates no downmixing is taking place.

DATA RATE: 32-640kb, depending on the data rate of the incoming signal.

SAMPLE RATE: 44.1kHz or 48kHz depending on the incoming signal.

PGM CONTENT: shows you the actual spatial characteristics of the incoming soundtrack. The information appears as **F/S.LFE** where **F**=the number of front channels and **S**=the number of surround channels. **LFE=.1** if the LFE channel is on.

For example, a given source may display **3/2.1**, indicating that the source was recorded with 3 front channels, 2 surround channels, and the LFE channel. When the designation **.1** indicates that the LFE channel is on, as in our example, a level meter at the bottom of the display will show LFE channel activity. (Note, that there are instances where the LFE channel is on, but no activity shows in the meter display. This is normal and should not cause concern.)

REF OFFSET indicates the Dialog Normalization value that is present in AC-3 bitstreams. In AC-3, dialog is reproduced at -31dBFS (31dB below full scale). If the program material was mixed so that dialog is at -31dBFS, then **REF OFFSET=0dB**. If the dialog was mixed at a "hotter" level, for example, -21dBFS, then **REF OFFSET = -10dB** and the DC-1 would adjust the levels down 10dB to bring dialog back to -31dB.

This Effect, available only in DC-1's equipped with Dolby Digital processing, enhances playback of Dolby Digital music recordings, or Dolby Digital film soundtracks with strong musical content. This effect contains many of the features found in 5.1 LOGIC 7, with settings that are more appropriate for music.

5.1 Music (Dolby Digital)

Parameter	Initial Value	Range
AC-3 STATUS (display only — not user adjustable)		
COMPRESSION	Off	Off, On, AUTO
RE-EQUALIZER	Off	On, Off
SURROUND LEVEL	0dB	-5 to +5dB
REAR DLY OFFSET	0ms	0-20ms
LFE MIX LEVEL	+0.0dB	-10dB to 0dB
SUBWOOFER LVL	+0dB	-5 to +5dB
CUSTOM		

5.1 Music Parameters

AC-3 STATUS displays the current status of incoming AC-3 data. The displayed items are not user adjustable.

COMPRESSION enhances the intelligibility of Dolby Digital material at low volume levels (-6dB or lower). When set to AUTO, this control automatically limits peak signals and boosts low level signals. The amount of compression increases proportionately as volume is decreased. This is quite useful when listening to Dolby Digital soundtracks at low output levels. When set to ON, full compression is applied, regardless of volume.

RE-EQUALIZER equalizes the left, center, and right channel outputs to match the overall frequency balance of the original recording. Without this re-equalization, many films and some television programs will sound too bright.

SURROUND LEVEL controls the volume level of the side and rear speakers. Although we have selected a default value, the correct setting will vary with each recording, the room, and your personal taste.

REAR DELAY OFFSET is an additional delay added to the rear channels when listening to LOGIC 7 and MUSIC SURROUND. This delay increases the apparent size of the listening space by increasing the rear delay time. Feel free to experiment to find the setting that works best.

LFE MIX LEVEL allows separate level attenuation of the LFE channel, which is ultimately mixed to the subwoofer output. As the bass from as many as five other channels is added to the LFE, it can significantly raise subwoofer output levels — and create the risk of damage to a system. Careful adjustment of this parameter will allow you to achieve proper tonal balance and reduce the risk of damage.

SUBWOOFER LVL boosts or cuts the subwoofer output level. Although the normal subwoofer level is set during the calibration procedure, with some recordings it may be desirable to increase or decrease this deep bass level.

Dolby Digital (Dolby Digital version)

Available only in the Dolby Digital version of the DC-1, the Dolby Digital effect decodes Dolby AC-3 encoded soundtracks. Unlike analog Dolby surround decoding, Dolby Digital uses five discrete full-range channels and a sixth dedicated, Low Frequency Effect (LFE) channel. In this effect, any rear speakers present are connected in parallel with the side speakers. This is the basic Dolby AC-3 effect. It does not include the enhancements by Lexicon or LucasFilm which are available with other AC-3 effects in the DC-1.

Dolby Digital Parameters

Parameter	Initial Value	Range
AC-3 STATUS (display only — not user adjustable)		
COMPRESSION	Off	Off, On, AUTO
DIALOG ENHANCE	+0.0dB	+0.0dB, +3.0dB, +6.0dB
LFE MIX LEVEL	+0.0dB	-10.0db to +0.0dB
SUBWOOFER LVL	+0dB	-5 to +5dB
CUSTOM		

AC-3 STATUS displays the current status of incoming AC-3 data. The displayed items are not user adjustable.

COMPRESSION enhances the intelligibility of Dolby Digital material at low volume levels (-6dB or lower). When set to AUTO, this control automatically limits peak signals and boosts low level signals. The amount of compression increases proportionately as volume is decreased. This is quite useful when listening to Dolby Digital soundtracks at low output levels. When set to ON, full compression is applied, regardless of volume.

DIALOG ENHANCE boosts dialog in the center channel. By targeting specific frequencies, it can boost only dialog, without raising the entire center channel level (which would alter the output balance achieved during calibration).

LFE MIX LEVEL allows separate level attenuation of the LFE channel, which is ultimately mixed to the subwoofer output. As the bass from as many as five other channels is added to the LFE, it can significantly raise subwoofer output levels — and create the risk of damage to a system. Careful adjustment of this parameter will allow you to achieve proper tonal balance and reduce the risk of damage.

SUBWOOFER LVL boosts or cuts the subwoofer output level. Although the normal subwoofer level is set during the calibration procedure, with some recordings it may be desirable to increase or decrease this deep bass level.

This Effect, available only in DC-1's equipped with Dolby Digital processing, provides THX 5.1 Cinema enhancements for film soundtracks recorded in the Dolby Digital format. This processing compensates for the acoustical differences between large mixing theaters and the typically smaller home environment. In this effect the side and rear speakers are driven in parallel when you designate side speakers as STANDARD (LARGE or SMALL) in the Speaker Configuration menu.

THX 5.1 (Dolby Digital version)

Parameter	Initial Value	Range
AC-3 STATUS (display only — not user adjustable)		
COMPRESSION	Off	Off, On, AUTO
RE-EQUALIZER	On	On, Off
LFE MIX LEVEL	+0.0dB	-10.0dB to 0.0dB
SUBWOOFER LVL	+0dB	-5 to +5dB
CUSTOM		

THX 5.1 Parameters

AC-3 STATUS displays the current status of incoming AC-3 data. The displayed items are not user adjustable.

COMPRESSION enhances the intelligibility of Dolby Digital material at low volume levels (-6dB or lower). When set to AUTO, this control automatically limits peak signals and boosts low level signals. The amount of compression increases proportionately as volume is decreased. This is quite useful when listening to Dolby Digital soundtracks at low output levels. When set to ON, full compression is applied, regardless of volume.

RE-EQUALIZER equalizes the left, center, and right channel outputs to match the overall frequency balance of the original recording. Without this re-equalization, many films and some television programs will sound too bright.

LFE MIX LEVEL allows separate level attenuation of the LFE channel, which is ultimately mixed to the subwoofer output. As the bass from as many as five other channels is added to the LFE, it can significantly raise subwoofer output levels — and create the risk of damage to a system. Careful adjustment of this parameter will allow you to achieve proper tonal balance and reduce the risk of damage.

SUBWOOFER LVL boosts or cuts the subwoofer output level. Although the normal subwoofer level is set during the calibration procedure, with some recordings it may be desirable to increase or decrease this deep bass level.

5.1 Logic 7 (Dolby Digital version)

5.1 Logic 7 combines all the features of Dolby Digital AC-3 with enhancements by Lexicon and LucasFilm. This effect uses Logic 7 matrix technology to enhance the steering between the side speakers and the rear speakers, so sounds intended to come from behind the listener actually do come from behind. This effect also includes the adaptive decorrelation and re-equalizer features of THX 5.1.

5.1 Logic 7 provides the ultimate in film reproduction. It brings out all the increased excitement and spaciousness a 7 channel speaker system can produce.

5.1 Logic 7 Parameters

Parameter	Initial Value	Range
AC-3 STATUS (display only — not user adjustable)		
COMPRESSION	Off	Off, On, AUTO
DIALOG ENHANCE	+0.0dB	+0.0dB, +3.0dB, +6.0dB
RE-EQUALIZER	Off	On, Off
REAR DELAY OFFSET	0ms	0-20ms
SURROUND LEVEL	+3dB	-5 to +5dB
LFE MIX LEVEL	+0.0dB	-10.0db to 0.0dB
SUBWOOFER LVL	+0dB	-5 to +5dB
EFFECT LEVEL	0dB	-30dB to +05dB
CUSTOM		

AC-3 STATUS displays the current status of incoming AC-3 data. The displayed items are not user adjustable.

COMPRESSION enhances the intelligibility of Dolby Digital material at low volume levels (-6dB or lower). When set to AUTO, this control automatically limits peak signals and boosts low level signals. The amount of compression increases proportionately as volume is decreased. This is quite useful when listening to Dolby Digital soundtracks at low output levels. When set to ON, full compression is applied, regardless of volume.

DIALOG ENHANCE boosts dialog in the center channel. By targeting specific frequencies, it can boost only dialog, without raising the entire center channel level (which would alter the output balance achieved during calibration).

RE-EQUALIZER equalizes the left, center, and right channel outputs to match the overall frequency balance of the original recording. Without this re-equalization, many films and some television programs will sound too bright.

REAR DELAY OFFSET is an additional delay added to the rear channels. This delay increases the apparent size of the listening space by increasing the rear delay time. Feel free to experiment to find the setting that works best.

SURROUND LEVEL controls the volume level of the side and rear speakers. Although we have selected a default value, the correct setting will vary with each recording, the room, and your personal taste.

LFE MIX LEVEL allows separate level attenuation of the LFE channel, which is ultimately mixed to the subwoofer output. As the bass from as many as five other channels is added to the LFE, it can significantly raise subwoofer output levels — and create the risk of damage to a system. Careful adjustment of this parameter will allow you to achieve proper tonal balance and reduce the risk of damage.

SUBWOOFER LVL boosts or cuts the subwoofer output level. Although the normal subwoofer level is set during the calibration procedure, with some recordings it may be desirable to increase or decrease this deep bass level.

EFFECT LEVEL adjusts the loudness of the center, side and rear speakers.

5.1 Two Channel (Dolby Digital version)

This Effect mixes Dolby Digital 5.1 information for two-channel playback. These soundtracks can be recorded onto two-channel formats, or played back through left and right front speakers. The mix is designed to play back with full surround when decoded through Logic 7. In mixing a film with very heavy use of the Low Frequency Effects Channel, it may be desirable to lower LFE MIX LEVEL.

5.1 Two Channel Parameters

Parameter	Initial Value	Range
AC-3 STATUS (display only — not user adjustable)		
LFE MIX LEVEL	+0.0dB	-10dB to 0dB
SURROUND MIX	+2dB	-5 to +5dB
SUBWOOFER LVL	+0dB	-5 to +5dB
CUSTOM		

AC-3 STATUS displays the current status of incoming AC-3 data. The displayed items are not user adjustable.

LFE MIX LEVEL allows separate level attenuation of the LFE channel, which is ultimately mixed to the subwoofer output. As the bass from as many as five other channels is added to the LFE, it can significantly raise subwoofer output levels — and create the risk of damage to a system. Careful adjustment of this parameter will allow you to achieve proper tonal balance and reduce the risk of damage.

SURROUND MIX allows independent adjustment of the level of the surround channels. Many AC-3 encoded soundtracks sound better when down-mixed to two channels with the surround level increased by approximately 2-3dB.

SUBWOOFER LVL boosts or cuts the subwoofer output level. Although the normal subwoofer level is set during the calibration procedure, with some recordings it may be desirable to increase or decrease this deep bass level.

If you encounter a problem, please review the items in the following checklist. Also be sure to thoroughly check all other connected components such as speakers, receiver/amplifier/preamp, VCR, TV, CD player, etc.

Troubleshooting

Problem	Possible Cause and Solution
Power does not come on	Check line cord to ensure good connection to the AC outlet and to the receptacle on the DC-1 rear panel. Check to make sure that the DC-1 rear panel power switch is ON.
No audio	Check input and output connections. They may be reversed relative to the IN and OUT jacks of your receiver/amplifier/preamp or other source.
Remote control not working	Check batteries to be certain that they are inserted correctly with proper polarity. Make sure that the infrared sensor on the DC-1 front panel is not obstructed. See "If all else fails..." on the following page.
No output	<p>Make sure that signal is coming into the DC-1. Increase VOLUME using the remote control and check Front/Back and Left/Right BALANCE.</p> <p>Check the DC-1-MUTE controls to make sure they are not engaged.</p> <p>Check all other equipment settings and connections and verify that the amplifiers being fed by the DC-1 are operational.</p> <p>Remember that the DC-1 mutes the output to any speakers which are not configured in the Setup menu. If speakers are added to (or removed from) your system, the Speaker Configuration menu must be altered accordingly.</p>
Center Channel only plays	Check to see if your HiFi VCR has dropped out of tracking — readjust. Your VCR Stereo/Mono/L-R switch may be in the wrong position — set it to Stereo.
Muffled sound in L&R channels	When no center channel is used, CENTER must be configured for NONE in the Setup Speaker Configuration menu.
Center channel sound muffled	The center channel amp may be connected to the subwoofer jack on the DC-1 rear panel. Reconnect to Center Output jack.
No Input Level Meters	The meters will only appear when adjusting the Gain parameter of a selected, active input.

Problem	Possible Cause and Solution
Hum	<p>Finding and eliminating audio hum in a complex installation can be a very frustrating task. Often, the easiest way to identify the culprit(s) is to systematically eliminate devices from the audio chain. If Cable TV is connected to any component in the system, start by unplugging the Cable completely, preferably right at the wall jack. If this eliminates, or greatly reduces the hum, it is worth a call to your Cable company. A quick fix, assuming your cable is round 75Ω wire, is to attach a 75-300Ω transformer to the end, then attach a 300-75Ω transformer to that, so that the end is back to a round 75Ω wire. There are commercially available antenna lead isolators which may provide additional insulation from electrical surges.</p>
Interference with Radio or TV	<p>The DC-1 does generate minimal amounts of RF energy and is in compliance with FCC rules and CE standards. If some interfering noise is noted, move AM loop and FM "T" type antennas away from the DC-1 and reorient them as necessary. Use shielded cable for FM and TV antenna feeds.</p>
Erratic recall of modes	<p>Severe power surges or sags can confuse the DC-1 memory. To correct, or if you simply want to start over, restore the factory defaults with the procedure described at the end of this section.</p>
If all else fails...	<p>Turn off all amplifiers. Turn the master power switch on the DC-1 rear panel OFF, wait 10 seconds, then turn it ON again. This causes the unit to run a diagnostic self-test routine which takes a couple of seconds. If the DC-1 LCD displays normally at the end of this test, no problems have been found with the DC-1 circuitry. If the internal tests fail, the LCD may display an error message, or no message at all. If this happens, contact Lexicon.</p> <p>If you find that your custom settings are routinely being corrupted, the lithium battery in the DC-1 may be faulty. This part is not field-replaceable — contact Lexicon.</p> <p>If the unit is still behaving erratically, perform the Restore Defaults procedure described on the following page.</p>

Other than occasional replacement of the batteries in the remote control units, the DC-1 requires minimal maintenance. Use a soft, lint-free cloth slightly dampened with warm water and a mild detergent to clean the exterior surfaces of the unit.

**Do not use alcohol, benzene or acetone-based cleaners
or any strong commercial cleaners.**

Avoid using any abrasive materials such as steel wool or metal polish. If the unit is exposed to a dusty environment, a vacuum or *low-pressure* blower may be used to remove dust from the DC-1 exterior.

Routine Maintenance

If severe power surges or sags cause problems with DC-1 memory storage, or you simply want to start with a clean slate, you can restore all of the factory defaults with the following procedure.

**This will erase any programs you have stored,
as well as all setup and calibration values.**

Note any settings you want to re-use before proceeding.

Restoring Defaults

Turn the DC-1 OFF with either the front panel switch or the remote. Turn the unit back ON and immediately press and hold BYPASS on the remote. (Make sure you do not block the infrared receiver on the DC-1 front panel.) The on-screen display will read:

FACTORY PRESETS MENU

EXIT

RESTORE DEFAULTS

If you want to resume normal operation *without* restoring all defaults, this is your last chance. Use MENU ▲ or ▼ to highlight EXIT, then press SELECT.

To restore defaults, use MENU ▲ or ▼ to highlight RESTORE DEFAULTS, then press SELECT. This will clear and reload all preset effects and all factory settings of Volume, Balance, Contrast, Configuration, etc.

When the message FACTORY DEFAULTS RESTORED is displayed, press DONE to return to normal operation. All of the adjustable parameters in the DC-1 have now been reset to the values assigned when it cleared final Quality Control at the factory.

If you cannot solve functional problems through these procedures, consult your dealer or Lexicon/Customer Service Department.

**DO NOT OPEN THE UNIT.
DOING SO WILL VOID YOUR WARRANTY,
AND MODIFICATIONS MAY RENDER THE UNIT UNSERVICEABLE.**

Specifications

Inputs: Audio: 8 stereo (RCA) pairs
 Minimum Input Level: 500 mVrms for maximum output
 200 mVrms for Dolby level (Input Gain=0dB)
 Input Impedance: 100 kΩ in parallel with 150pF

Video: 5 composite (RCA), 3 S-video, NTSC, PAL, SECAM compatible
 Input Level and Impedance: 1Vpp, 75Ω

Digital: 4: 2 coaxial (RCA), 2 optical (TOSLINK™),
 conforms to S/PDIF standard

Outputs: Audio: 8 outputs:Left, Center,Right, L&R Sides, L&R Rears, Subwoofer (RCA)
 Maximum Output Level: 6 Vrms (System Volume=+12dB)
 Output Impedance: 100 Ω in parallel with 150pF

Video: 2 composite (RCA), 2 S-video, NTSC, PAL, SECAM compatible
 Output Level and Impedance: 1V p-p, 75Ω

PWR CTL:	Minimum Output	Maximum Output	Maximum Current Out
12 volts (default)	11.5 volts	15.3 volts	140mA
5 volts	3.3 volts	5.1 volts	200mA

D/A Conversion: 20-bit Delta-Sigma

Frequency Response: 10 Hz-20 kHz, ±0.5dB, Ref. 1kHz

THD+Noise: Less than 0.01% @1kHz, maximum output level

Dynamic Range: 90dB minimum, 22kHz bandwidth,
 Ref. 1kHz@ -60dB below maximum output level

Signal to Noise Ratio: 90dB minimum, 22kHz bandwidth, Ref. 1kHz at maximum output level

Power Requirements: 100-240 VAC, 50-60Hz 35Watts (universal input)
 IEC detachable power cord provided per country of destination

Dimensions: 17.3"W x 11.5"D x 3.6"H (440 x 292 x 92mm)
 19.0"W x 11.5"D x 3.5"H (483 x 292 x 89mm) with rack mounting brackets

Weight: 10.5 lbs. (4.8kg)

Environment: Operating Temperature: 32° to 95°F (0° to 35°C)
 Storage Temperature: -22° to 167°F (-30° to 75°C)
 Relative Humidity: 95% maximum without condensation

Remote Controls: 1 hand-held, battery-powered remote control unit uses 2 AAA alkaline batteries

Specifications subject to change without notice.

Installation Worksheet

Model/Serial # _____ / _____

Installed by _____ Phone _____ Date _____

Inputs						
VCR1	Gain _____	Name _____	Effect _____	AC-3 FX _____	Digital _____	Video _____
	Rec/Zone2: <input type="checkbox"/> Analog <input type="checkbox"/> Digital <input type="checkbox"/> Blocked			Trigger: <input type="checkbox"/> enabled <input type="checkbox"/> disabled		
VCR2	Gain _____	Name _____	Effect _____	AC-3 FX _____	Digital _____	Video _____
	Rec/Zone2: <input type="checkbox"/> Analog <input type="checkbox"/> Digital <input type="checkbox"/> Blocked			Trigger: <input type="checkbox"/> enabled <input type="checkbox"/> disabled		
V-DISC	Gain _____	Name _____	Effect _____	AC-3 FX _____	Digital _____	Video _____
	Rec/Zone2: <input type="checkbox"/> Analog <input type="checkbox"/> Digital <input type="checkbox"/> Blocked			Trigger: <input type="checkbox"/> enabled <input type="checkbox"/> disabled		
TV	Gain _____	Name _____	Effect _____	AC-3 FX _____	Digital _____	Video _____
	Rec/Zone2: <input type="checkbox"/> Analog <input type="checkbox"/> Digital <input type="checkbox"/> Blocked			Trigger: <input type="checkbox"/> enabled <input type="checkbox"/> disabled		
AUX	Gain _____	Name _____	Effect _____	AC-3 FX _____	Digital _____	Video _____
	Rec/Zone2: <input type="checkbox"/> Analog <input type="checkbox"/> Digital <input type="checkbox"/> Blocked			Trigger: <input type="checkbox"/> enabled <input type="checkbox"/> disabled		
CD	Gain _____	Name _____	Effect _____	AC-3 FX _____	Digital _____	Video _____
	Rec/Zone2: <input type="checkbox"/> Analog <input type="checkbox"/> Digital <input type="checkbox"/> Blocked			Trigger: <input type="checkbox"/> enabled <input type="checkbox"/> disabled		
TUNER	Gain _____	Name _____	Effect _____	AC-3 FX _____	Digital _____	Video _____
	Rec/Zone2: <input type="checkbox"/> Analog <input type="checkbox"/> Digital <input type="checkbox"/> Blocked			Trigger: <input type="checkbox"/> enabled <input type="checkbox"/> disabled		
TAPE	Gain _____	Name _____	Effect _____	AC-3 FX _____	Digital _____	Video _____
	Rec/Zone2: <input type="checkbox"/> Analog <input type="checkbox"/> Digital <input type="checkbox"/> Blocked			Trigger: <input type="checkbox"/> enabled <input type="checkbox"/> disabled		

OSD Position bottom center top

Display Time always on 2 sec. time out always off

Speaker Configuration (circle selection)

FRONT	LG	SM	80	100	120				
CENTER	LG	SM	NONE	80	100	120			
SIDES	LG	LG	SM	SM	NONE	80	100	120	
	STD	DIP	STD	DIP					
REARS	LG	SM	NONE	80	100	120			
SUBWFR	YES	NO	OFF	80	100	120			

Listener Position (Panorama)

Speaker Listener Angle _____°
 Listener Position _____

Output Levels	Speaker Distance	Wiring Comments	Output Levels	Speaker Distance	Wiring Comments
L. Front _____dB	_____	_____	L. Side _____dB	_____	_____
Center _____dB	_____	_____	Sub _____dB	_____	_____
R. Front _____dB	_____	_____	R. Rear _____dB	_____	_____
R. Side _____dB	_____	_____	L. Rear _____dB	_____	_____

Lexicon, Inc.
3 Oak Park,
Bedford MA 01730-1441 USA
Telephone: 781-280-0300
Fax: 781-280-0490
www.lexicon.com